

# Instruction Manual

## HT10 and HT16 High Throughput Diffusion Pumps

Description	Voltage	Item Numbers		
		ANSI10/ANSI2 Inlet/Outlet	EO 12 inch/EO 130 mm Inlet/Outlet	ISO320/ISO63 Inlet/Outlet
HT10 High Throughput Diffusion Pumps	200 V	B311-01-200	B311-02-200	B311-03-200
	220 V	B311-01-220	B311-02-220	B311-03-220
	380 V	B311-01-380	B311-02-380	B311-03-380
	400 V	B311-01-400	B311-02-400	B311-03-400
	415 V	B311-01-415	B311-02-415	B311-03-415
	440 V	B311-01-440	B311-02-440	B311-03-440
	460 V	B311-01-460	B311-02-460	B311-03-460
	480 V	B311-01-480	B311-02-480	B311-03-480
Description	Voltage	Item Numbers		
		ANSI16/ANSI3 Inlet/Outlet		ISO500/ISO100 Inlet/Outlet
HT16 High Throughput Diffusion Pumps	200 V	B312-04-200		B312-05-200
	220 V	B312-04-220		B312-05-220
	380 V	B312-04-380		B312-05-380
	400 V	B312-04-400		B312-05-400
	415 V	B312-04-415		B312-05-415
	440 V	B312-04-440		B312-05-440
	460 V	B312-04-460		B312-05-460
	480 V	B312-04-480		B312-05-480





# Declaration of Conformity

We, Edwards,  
Innovation Drive,  
Burgess Hill,  
West Sussex,  
RH15 9TW, UK

declare under our sole responsibility, as manufacturer and person within the EU authorised to assemble the technical file, that the product(s)

HT10 Vapour Diffusion Pumps:

B311-01-200, B311-01-220, B311-01-240, B311-01-380, B311-01-400, B311-01-415,  
B311-01-460, B311-01-480, B311-02-200, B311-02-220, B311-02-240, B311-02-380,  
B311-02-400, B311-02-415, B311-03-200, B311-03-220, B311-03-240, B311-02-380,  
B311-03-400, B311-03-415, B311-03-480

to which this declaration relates is in conformity with the following standard(s) or other normative document(s)

EN1012-2:1996+A1:2009 Compressors and Vacuum Pumps. Safety Requirements. Vacuum Pumps  
EN60204-1: 2006 Safety of machinery. Electrical equipment of machines.  
+ A1: 2009 General Requirements

and fulfils all the relevant provisions of

2014/35/EU Low Voltage Directive

*Note: This declaration covers all product serial numbers from the date this Declaration was signed onwards.*

Mr Peter Meares  
Senior Technical Support Manager, General Vacuum

13.05.2016, Burgess Hill

Date and Place

*This product has been manufactured under a quality management system certified to ISO 9001:2008*

## Materials Declaration

In accordance with the requirements of the Chinese regulatory requirement on the Management Methods for the Restriction of the Use of Hazardous Substances in Electrical and Electronic Products Order No. 32 (also known as 'China RoHS2') and SJ/T 11364 Marking for the Restricted Use of Hazardous Substances in Electronic and Electrical Products:

### Product Labels

Product	Product Label	Meaning
All pumps in the list below		This product contains hazardous substances in at least one of the homogeneous materials used which are above the limit requirement in GB/T 26572 as detailed in the declaration table below. These parts can safely be used for the environmental protection use period as indicated.

Pump Type	Pump Size
Diffusion Pumps	Diffstak 63, 100, 160, 250
Vapour Boosters	30B5, 18B4
High Throughput Pumps	HT10, 16, 20

### 材料成分声明

### Materials Content Declaration





部件名称 Part name	危险物质 Hazardous Substances					
	铅 Lead (Pb)	汞 Mercury (Hg)	镉 Cadmium (Cd)	六价铬 Hexavalent Chromium (Cr VI)	多溴联苯 Polybrominated biphenyls (PBB)	多溴二苯醚 Polybrominated diphenyl ethers (PBDE)
铸铝 Cast Aluminium	X	O	O	O	O	O
铜管管件 Brass pipe Fittings	X	O	O	O	O	O
铜接头 Brass Connectors	X	O	O	O	O	O

O : 表示该有害物质在该部件的所有均质材料中的含量低于 GB/T 26572 标准规定的限量要求。  
O: Indicates that the hazardous substance contained in all of the homogeneous materials for this part is below the limit requirement in GB/T 26572.

X : 表示该有害物质在该部件的至少一种均质材料中的含量超出 GB/T26572 标准规定的限量要求。  
X: Indicates that the hazardous substance contained in at least one of the homogeneous materials used for this part is above the limit requirement of GB/T26572.

NOTES: These products are EU RoHS compliant, the following Exemptions apply:  
6(b) Lead as an alloying element in aluminium containing up to 0.4% by weight.  
6(c) Copper alloy containing up to 4% lead by weight

### Packaging Information

Pallet	Over-shipper	Protection Pieces	Support Braces
			
Recyclable Natural Wood	Recyclable Cardboard	Recyclable Polypropylene	Recyclable Mild Steel

This page intentionally blank.

# Contents

Section	Page
<b>1</b>	<b>Introduction</b> ..... 1
1.1	Scope and definitions ..... 1
1.2	Description ..... 2
1.2.1	HT10 and HT16 Diffusion Pumps ..... 2
1.2.2	Pump-inlet and outlet sizes ..... 2
1.2.3	Drain/fill assembly ..... 2
1.2.4	Over-temperature and auxiliary protection ..... 3
1.3	Performance ..... 3
1.4	Operation with high ambient humidity ..... 3
<b>2</b>	<b>Technical data</b> ..... 9
2.1	Performance and operating conditions ..... 9
2.2	Pump warm-up and cool-down curves ..... 9
2.3	Mechanical data ..... 10
2.4	Electrical data ..... 10
2.5	Pump fluid data ..... 11
2.6	Construction details ..... 11
<b>3</b>	<b>Installation</b> ..... 17
3.1	Unpack and Inspect ..... 17
3.2	Locate the pump ..... 17
3.3	Electrical connections ..... 18
3.3.1	Pump electrical supply ..... 18
3.3.2	Over-temperature protection ..... 20
3.3.3	Auxiliary plug connections ..... 20
3.3.4	Indicator trip ..... 20
3.4	Cooling-water connections ..... 22
3.5	Vacuum connections ..... 22
3.6	Leak-test the system ..... 23
3.7	Fill the pump with fluid ..... 23
3.7.1	Safety of vapour pump fluids ..... 23
3.7.2	Recommended pump fluids ..... 23
3.7.3	Filling procedure ..... 23
<b>4</b>	<b>Operation</b> ..... 25
4.1	Introduction ..... 25
4.2	Check the insulation resistance of the heaters ..... 26
4.3	Pump start-up ..... 26
4.3.1	Fully-valved pumping system ..... 26
4.3.2	Partially-valved pumping system ..... 27
4.3.3	Valveless pumping system ..... 27
4.4	Process cycling ..... 27
4.4.1	Re-admission of air to your vacuum system ..... 27
4.4.2	Re-evacuate your vacuum system ..... 27
4.5	Pump shut-down ..... 28
4.5.1	Introduction ..... 28
4.5.2	Fully-valved pumping systems ..... 28
4.5.3	Partially-valved pumping systems ..... 30
4.5.4	Valveless pumping systems ..... 30
<b>5</b>	<b>Maintenance</b> ..... 31

5.1	Safety .....	31
5.2	Maintenance plan .....	32
5.3	Check the pump fluid-level .....	32
5.4	Inspect and drain the pump fluid .....	32
5.5	Clean the pump .....	33
5.5.1	Clean the HT10 pump .....	33
5.5.2	Clean the HT16 pump .....	34
5.6	Clean the condenser assembly .....	35
5.7	Clean the cooling-coils .....	35
5.8	Replace the thermal snap-switch .....	35
5.9	Heater maintenance .....	36
5.9.1	Remove the heaters .....	36
5.9.2	Fit the new heaters .....	37
5.10	Replace electrical components .....	37
5.11	Fault finding .....	40
5.11.1	The pump will not start .....	40
5.11.2	The pump shuts down .....	40
5.11.3	The pump fails to achieve specified performance .....	40
5.11.4	High-pressure pumping speeds (above $1 \times 10^{-3}$ mbar, $1 \times 10^{-1}$ Pa) are poor .....	41
5.11.5	Pumping is unstable .....	41
5.11.6	Pressure is unstable .....	41
5.11.7	Backstreaming is excessive .....	41
5.11.8	Pump fluid loss is excessive .....	41
<b>6</b>	<b>Storage and disposal .....</b>	<b>43</b>
6.1	Storage .....	43
6.2	Disposal .....	43
<b>7</b>	<b>Service, spares and accessories .....</b>	<b>45</b>
7.1	Introduction .....	45
7.2	Service .....	45
7.3	Spares .....	45
7.3.1	HT10 spares .....	46
7.3.2	HT16 spares .....	46
7.3.3	Spares common to HT10 and HT16 .....	47
7.4	Accessories .....	47
7.4.1	Thermal probe .....	47
7.4.2	Heat shield .....	47
7.4.3	Inlet baffle .....	48

## Illustrations

Figure	Page
1 HT10 pump sectional view .....	4
2 HT16 pump sectional view .....	6
3 Pump dimensions (mm): HT10 shown .....	12
4 HT10 performance curves .....	13
5 HT16 performance curves .....	14
6 Pump warm-up curves: temperature of base flange (°C) plotted against time .....	15
7 Pump cool-down curves: temperature of base flange (°C) plotted against time .....	15
8 Pump electrical block diagram .....	19
9 Auxiliary plug wiring .....	21
10 Terminal-box (with cover removed) .....	21
11 Fully-valved pumping system .....	29
12 Partially-valved pumping system .....	29
13 Valveless pumping system .....	29
14 Thermal snap-switches .....	36
15 HT10 pump base (with outer radiation shield removed) .....	38
16 HT16 pump base (with outer radiation shield removed) .....	39

## Tables

Table	Page
1 Performance and operating conditions data .....	9
2 Mechanical data .....	10
3 Electrical data .....	10
4 Pump fluid data .....	11
5 Construction consumables .....	11
6 Construction materials .....	11
7 Checklist of items .....	17
8 Vapour pump fluid thermal breakdown .....	24
9 Maintenance plan .....	32

## Associated publications

Publication title	Publication number
HT Pump Accessories	B611-01-880

## Tradename credits

Apiezon® is a registered trademark of M & I Materials.

Santovac® is a registered trademark of Santovac Fluids Inc.



# 1 Introduction

## 1.1 Scope and definitions

This manual provides installation, operation and maintenance instructions for the Edwards HT10 and HT16 High Throughput Diffusion Pumps. You must use the HT10 and HT16 pumps as specified in this manual.

Read this manual before you install and operate the pump. Important safety information is highlighted as WARNING and CAUTION instructions; you must obey these instructions. The use of WARNINGS and CAUTIONS is defined below.



### **WARNING**

Warnings are given where failure to observe the instruction could result in injury or death to people.

### **CAUTION**

Cautions are given where failure to observe the instruction could result in damage to the equipment, associated equipment and process.

The following IEC warning labels appear on the pump:



Warning - refer to accompanying documentation.



Warning - risk of electric shock.



Warning - hot surface.



Protective conductor terminal.

The units used throughout this manual conform to the SI international system of units of measurement.

## 1.2 Description

### 1.2.1 HT10 and HT16 Diffusion Pumps

The HT10 and HT16 are water-cooled, high throughput diffusion pumps with built-in over-temperature protection. The component parts of the pumps are shown in Figures 1 and 2.

The pump has a welded tubular body assembly and a precision machined interior with accurate vapour jet gaps. The body assembly has an inlet-flange, a main body tube, a base and an outlet-condenser assembly. The pump is cooled by water which passes through a tubular copper coil attached to the body and configured to provide optimum cooling. There are three annular jet stages (four on the HT16) and a conical ejector jet stage. The top-jet has a cool-cap which reduces backstreaming without loss of pumping speed. In the HT16, the cool-cap is water-cooled to accommodate the higher operational temperature of the HT16.

These pumps are fractionating. This means that the higher vapour pressure fractions of the pump fluid are fed to the lower jets. The top-jet receives the lower vapour pressure fractions. This improves the ultimate vacuum of the pump.

### 1.2.2 Pump-inlet and outlet sizes

The HT10 pump is available with three different pump-inlet and outlet connection configurations and the HT16 pump is available with two different pump-inlet and outlet connection configurations.

These configurations are listed on the front cover and the following notation is used:

- 'ANSIxx' means an ANSI xx inch flange (for example, ANSI16 means an ANSI 16 inch flange)
- 'EO xx inch' means an Edwards xx inch flange (and, for example, 'EO 130 mm' means an Edwards 130 mm flange)
- 'ISOxx' means an ISOxx standard flange (for example, ISO320)

### 1.2.3 Drain/fill assembly

The boiler drain-plug and the fluid-level dipstick are located on the base of the pump, at the junction with the electrical-box cover. The dipstick is used to check the pump fluid-level. Removal of the dipstick also enables the pump to be filled with pump fluid.

### 1.2.4 Over-temperature and auxiliary protection

The pump has an over-temperature protection system. If the pump overheats due to either cooling failure or fluid loss, the heaters are switched off before serious damage occurs and before the pump fluid can go through a process of thermal breakdown (see [Section 3.7.1](#)).

The over-temperature protection system has a contactor controlled by two thermal snap-switches. One thermal snap-switch monitors the temperature of the cooling-coils and the other snap-switch monitors the temperature of the base of the pump.

The contacts of the thermal snap-switches open at a preset threshold temperature. Once opened, the snap-switches will automatically reset if the temperature of the pump drops below the threshold temperature. If the electrical supply fails during operation, the snap-switch contacts will not open and the pump will restart after the restoration of the electrical supply unless additional protection measures are used.

The over-temperature protection system is a low-voltage (24 V a.c.) series-switched circuit. You cannot use this circuit as an electrical supply to accessories.

A low-voltage (24 V a.c.) auxiliary circuit is wired in series with the thermal snap-switch assembly. This auxiliary circuit may be used to provide secondary protection. For example, it may be used in conjunction with a vacuum switch or controller to switch off the pump heaters if the backing pressure is too high. Connect to the auxiliary circuit through the auxiliary plug fitted to the electrical-box (see [Section 3.3](#)).

## 1.3 Performance

The pumping speeds and throughputs, given in [Section 2](#), were calculated from measurements made with total pressure gauges. If partial-pressure gauges are used, the calculated values for pumping speeds are approximately 30% larger. This is because partial-pressure gauges do not measure the pressure added to the system by condensable gases.

The HT pumping speeds were calculated with reference to international standards. If American Vacuum Society standards are used, the pumping speeds are approximately 10% larger.

We do not give values for the ultimate vacuum of the HT pumps. The ultimate vacuum depends on the fluid used in the pump, the leak tightness of the system, outgassing from surfaces and the use of cold traps.

## 1.4 Operation with high ambient humidity

When the pump is switched off, the heaters in the pump will absorb moisture: this will cause a decrease in the insulation resistance of the heaters. If you operate the pump in an environment with high ambient humidity, this may cause the heaters to fail. The rate of moisture absorption (and therefore the time taken for the insulation resistance of the heaters to fall below the recommended value) depends on the ambient humidity and temperature and the length of time that the pump is switched off.

In addition to the recommendations made in later sections of this manual, you can overcome the effect of high ambient humidity if you:

- Configure the electrical installation of the pump for 'soft-start' operation, when the pump is operated with typically 20 to 25% of the nominal supply voltage.
- Install an anti-moisture heater under the base of the pump. Switch on this heater when you switch off the pump.

Detailed information about these recommendations is outside the scope of this manual. If you need more information about the operation of the pump with high ambient humidity, request a copy of our Application Note P400-50-000 from your supplier or Edwards .

Figure 1 - HT10 pump sectional view

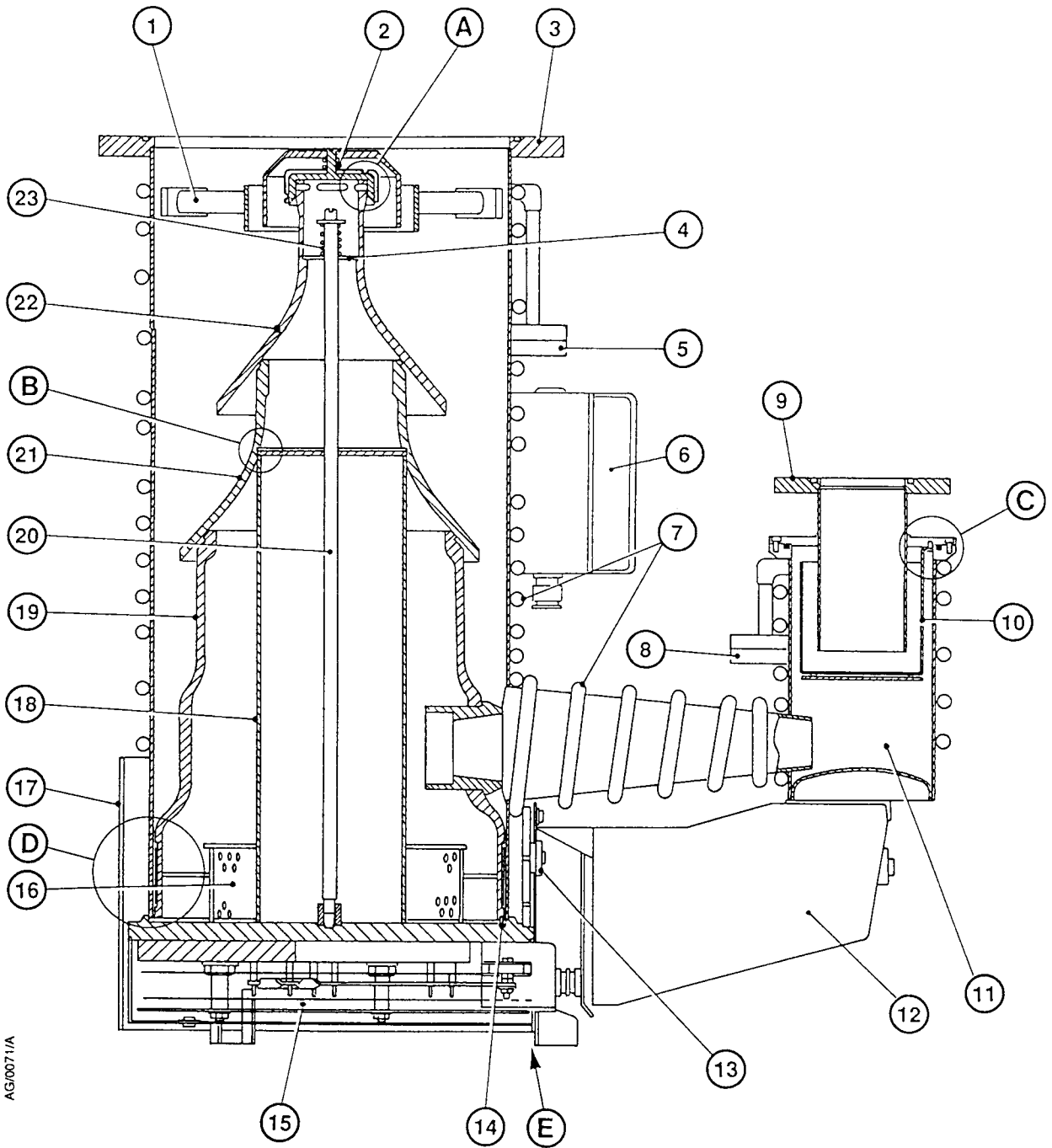

AG5/0071/A

Figure 1 - HT10 pump sectional view (continued)

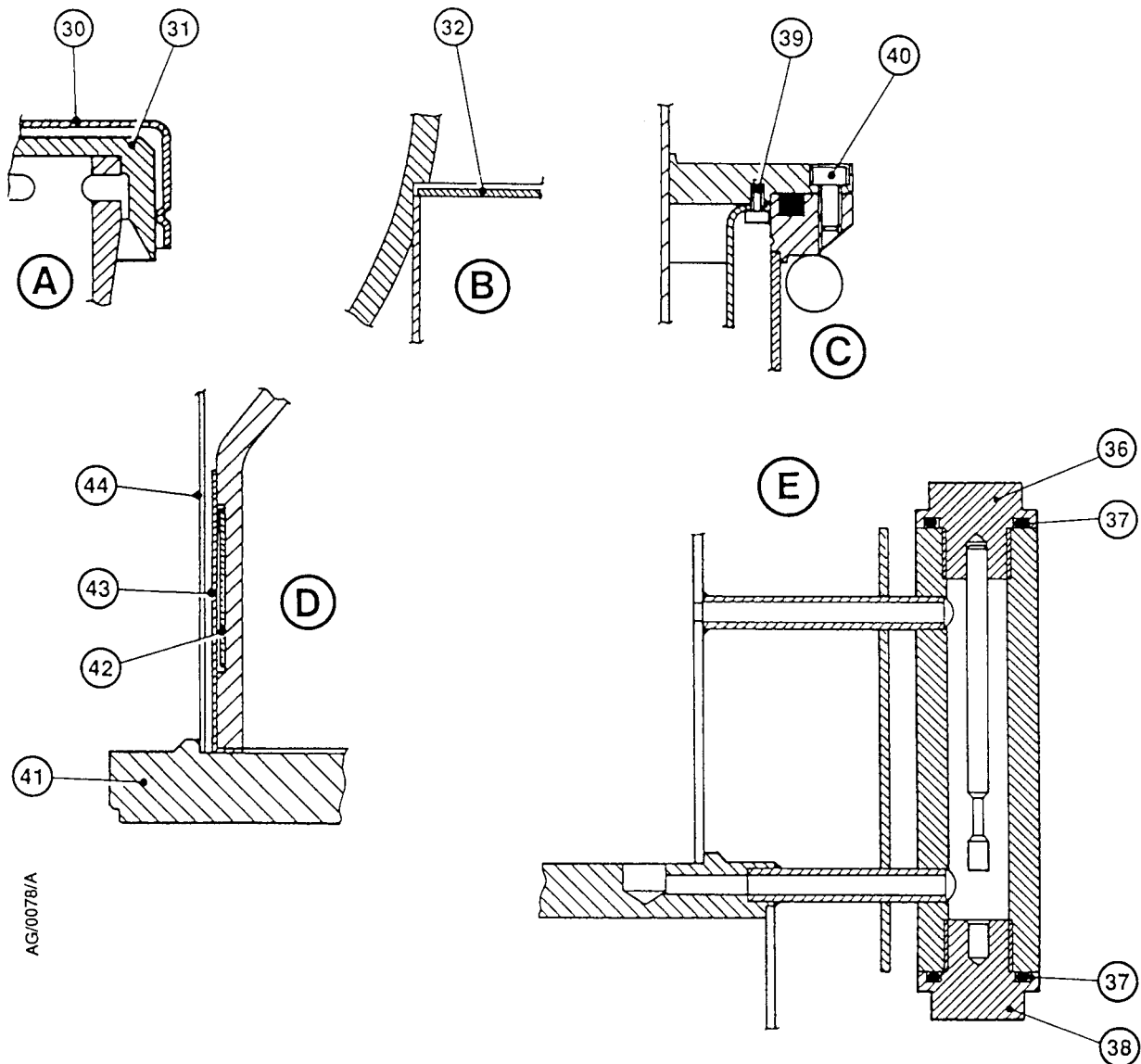

AG/0078/A

- |                                  |                                |                           |
|----------------------------------|--------------------------------|---------------------------|
| 1. Cool-cap assembly             | 16. Oil drier                  | 31. Top-jet cap           |
| 2. Spring                        | 17. Radiation shield           | 32. Second-stage disk     |
| 3. Inlet-flange                  | 18. Centre tube                | 33. Not used              |
| 4. Top-stage disk                | 19. Lower-stage                | 34. Not used              |
| 5. Water-inlet connection        | 20. Interior tie-rod           | 35. Not used              |
| 6. Terminal-box                  | 21. Second-stage               | 36. Dipstick/filler-plug  |
| 7. Cooling coils                 | 22. Top-stage                  | 37. O-rings               |
| 8. Water-outlet connection       | 23. Spring, disk and split-pin | 38. Drain-plug            |
| 9. Outlet-flange (backing line)  | 24. Not used                   | 39. Baffle mounting screw |
| 10. Baffle assembly              | 25. Not used                   | 40. Fixing screw          |
| 11. Outlet-condenser assembly    | 26. Not used                   | 41. Base flange           |
| 12. Electrical-box               | 27. Not used                   | 42. Inner thermal shield  |
| 13. Thermal snap-switch assembly | 28. Not used                   | 43. Outer thermal shield  |
| 14. Interior locating-pin        | 29. Not used                   | 44. Body tube             |
| 15. Base assembly                | 30. Secondary-cap              |                           |

Figure 2 - HT16 pump sectional view

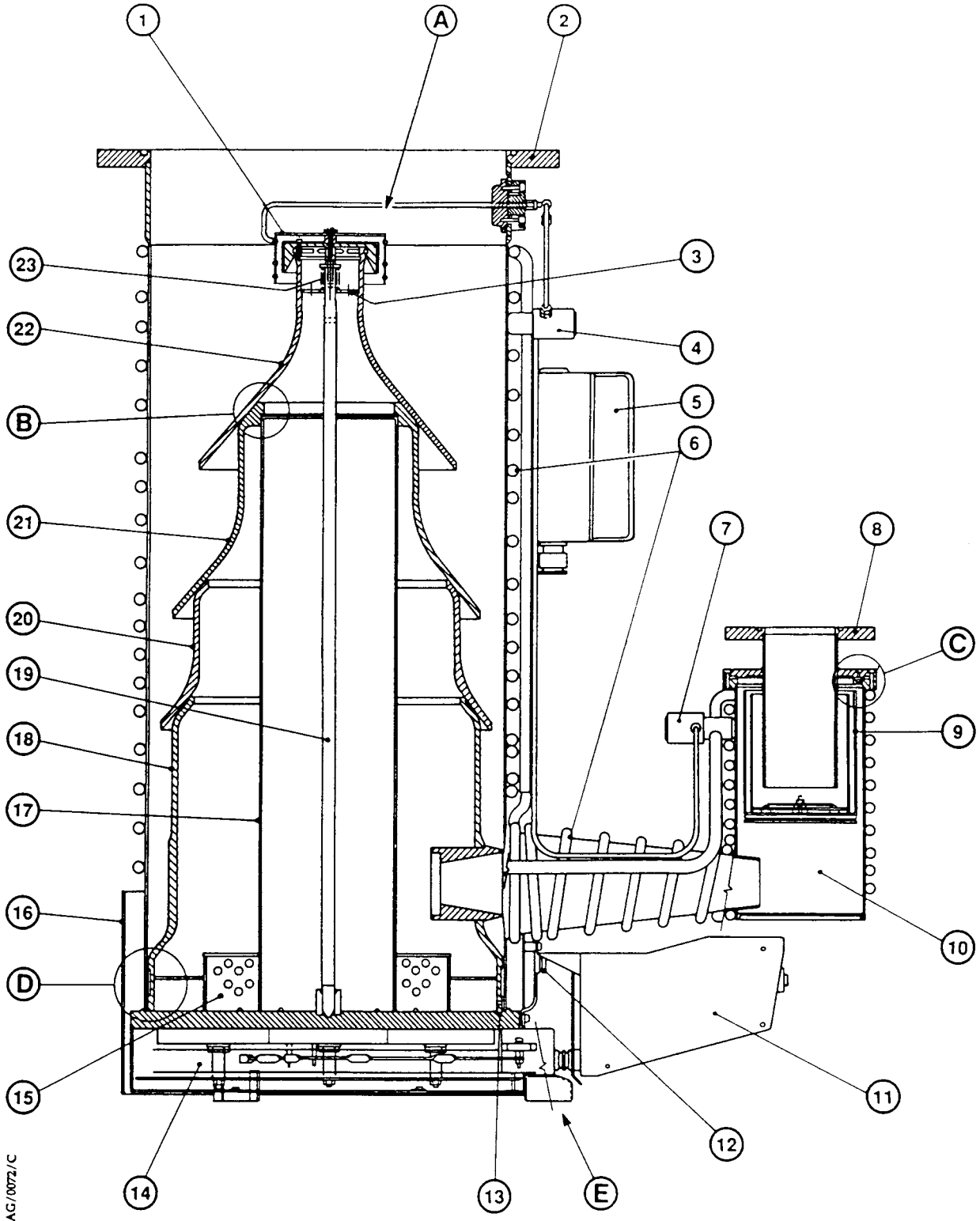

AG/0072/C

Figure 2 - HT16 pump sectional view (continued)

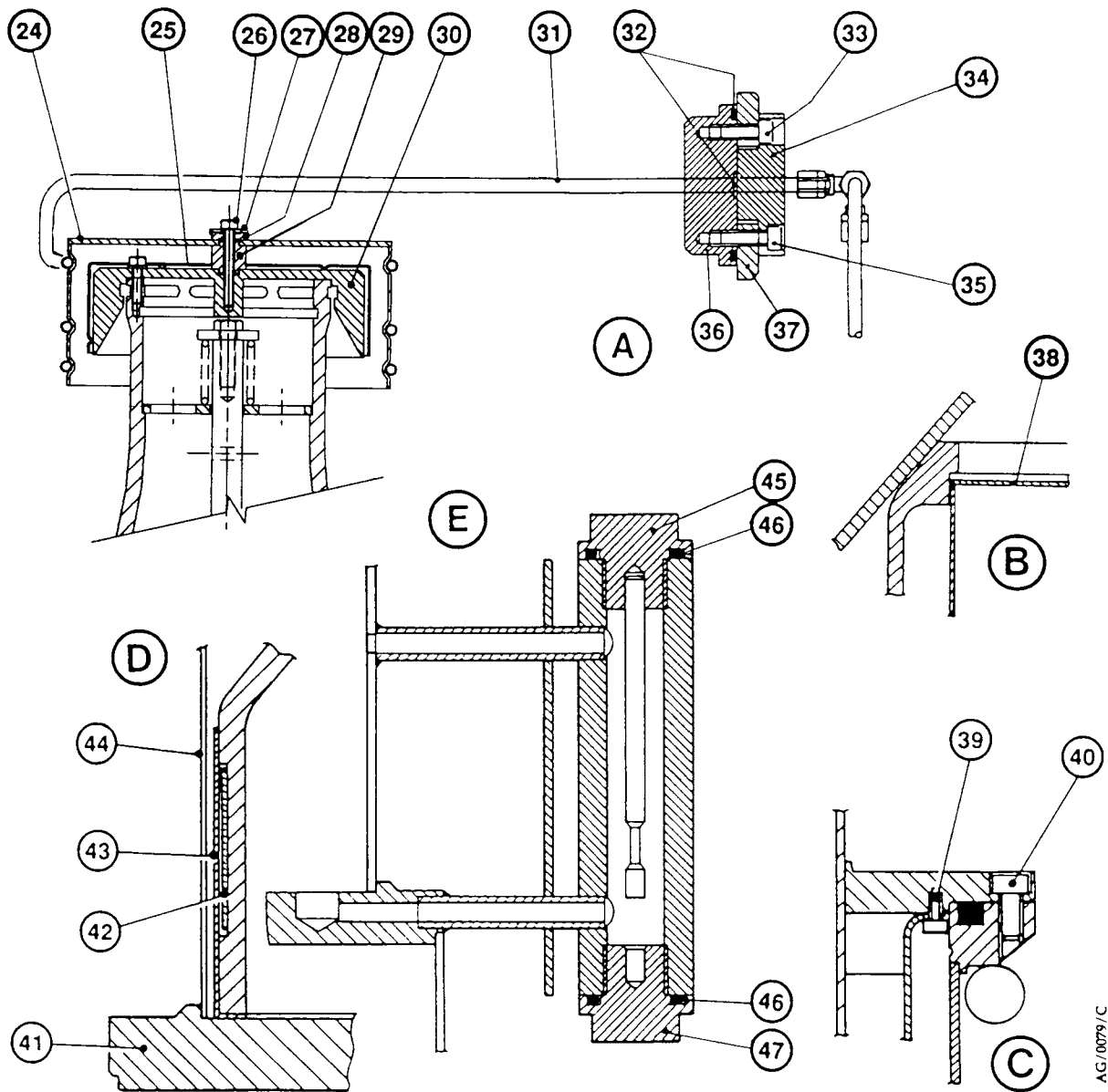

AG/0079/C

- |                                  |                                  |                           |
|----------------------------------|----------------------------------|---------------------------|
| 1. Cool-cap assembly             | 17. Centre tube                  | 33. Mounting screws       |
| 2. Inlet-flange                  | 18. Lower-stage                  | 34. Water boss            |
| 3. Top-stage disk                | 19. Interior tie-rod             | 35. Mounting screws       |
| 4. Water-inlet connection        | 20. Third-stage                  | 36. Body boss             |
| 5. Terminal-box                  | 21. Second-stage                 | 37. Connection flange     |
| 6. Cooling coils                 | 22. Top-stage                    | 38. Second-stage disk     |
| 7. Water-outlet connection       | 23. Spring, disk and fixing bolt | 39. Baffle mounting screw |
| 8. Outlet-flange (backing line)  | 24. Cool-cap                     | 40. Location pin          |
| 9. Baffle assembly               | 25. Secondary-cap                | 41. Base flange           |
| 10. Outlet-condenser assembly    | 26. Fixing screw                 | 42. Inner thermal shield  |
| 11. Electrical-box               | 27. Special washer               | 43. Outer thermal shield  |
| 12. Thermal snap-switch assembly | 28. Ceramic washer               | 44. Body tube             |
| 13. Interior locating-pin        | 29. Ceramic spacer               | 45. Dipstick/filler-plug  |
| 14. Base assembly                | 30. Top-jet cap                  | 46. O-rings               |
| 15. Oil drier                    | 31. Cooling-water tubes          | 47. Drain-plug            |
| 16. Radiation shield             | 32. O-rings                      |                           |

This page has been intentionally left blank.



## 2 Technical data

### 2.1 Performance and operating conditions

Table 1 - Performance and operating conditions data

	HT10	HT16
Performance curve *	See Figure 4	See Figure 5
Pumping speed (ISO)		
Nitrogen	3000 l s <sup>-1</sup>	6500 l s <sup>-1</sup>
Helium	4500 l s <sup>-1</sup>	7200 l s <sup>-1</sup>
Backstreaming rate at ultimate vacuum	1 x 10 <sup>-4</sup> mg cm <sup>-2</sup> min <sup>-1</sup>	1 x 10 <sup>-3</sup> mg cm <sup>-2</sup> min <sup>-1</sup>
Throughput at 4 x 10 <sup>-3</sup> mbar		
Nitrogen	10 mbar l s <sup>-1</sup> 1 x 10 <sup>-3</sup> Pa l s <sup>-1</sup>	17.5 mbar l s <sup>-1</sup> 1.75 x 10 <sup>-3</sup> Pa l s <sup>-1</sup>
Helium	16 mbar l s <sup>-1</sup> 1.6 x 10 <sup>-3</sup> Pa l s <sup>-1</sup>	29 mbar l s <sup>-1</sup> 2.9 x 10 <sup>-3</sup> Pa l s <sup>-1</sup>
Fluid loss at 4 x 10 <sup>-3</sup> mbar (4 x 10 <sup>-1</sup> Pa)	0.5 g h <sup>-1</sup>	0.7 g h <sup>-1</sup>
Critical backing pressure (with DC704EU fluid)	0.9 mbar, 90 Pa	1.4 mbar, 140 Pa
Maximum system pressure (absolute)	1.3 bar, 1.3 x 10 <sup>5</sup> Pa	1.3 bar, 1.3 x 10 <sup>5</sup> Pa
Minimum backing pump displacement for maximum throughput	60 m <sup>3</sup> h <sup>-1</sup>	94 m <sup>3</sup> h <sup>-1</sup>
Recommended Edwards backing pump	E2M80	E2M175
Warm-up time to operating temperature	30 min	60 min
Warm-up time to maximum throughput	45 min	75 min
Cool-down time (to approximately 100 °C)	120 min	180 min
Maximum ambient working temperature	40 °C	40 °C
Typical surface temperature	150 °C	150 °C
Maximum allowed water-outlet temperature	35 °C	35 °C
Minimum cooling-water flow	400 l h <sup>-1</sup> at 25 °C	700 l h <sup>-1</sup> at 25 °C
Pressure differential across cooling-water supply and return connections	1 bar (gauge), 2 x 10 <sup>5</sup> Pa	1 bar (gauge), 2 x 10 <sup>5</sup> Pa

\* As specified in Section 1.3, pump performance depends on a number of factors; Figures 4 and 5 show typical performance curves

### 2.2 Pump warm-up and cool-down curves

**Note:** The temperatures specified below and shown in Figures 6 and 7 were measured at the edges of the base flanges of the HT10 pump (Figure 1, Item 41) and the HT16 pump (Figure 2, Item 41). The temperatures and curves are therefore different from those specified for the thermal probe accessory in the EXT Accessories instruction manual.

Figure 6 shows the time for the pumps to warm-up from an ambient temperature of approximately 20 °C to a final operating temperature of approximately 210 °C for the HT10 and approximately 240 °C for the HT16.

Figure 7 shows the time for the pumps to cool down from operating temperature to approximately 90 °C.

## 2.3 Mechanical data

Table 2 - Mechanical data

	HT10	HT16
Dimensions	See Figure 3	See Figure 3
Mass	80 kg	185 kg
Inlet flange	ANSI10, EO 12 inch or IS320	ANSI16 or ISO500
Outlet flange	ANSI2, EO 130 mm or ISO63	ANSI3 or ISO100
Cooling-water connections	$\frac{3}{8}$ NPT female	$\frac{3}{4}$ NPT female
Maximum stability angle	20°	20°

## 2.4 Electrical data

Table 3 - Electrical data

	HT10	HT16
Heaters		
Number of heaters	3	6
Voltage	200, 220, 380, 400, 415, 440, 460 or 480 V	200, 220, 380, 400, 415, 440, 460 or 480 V
Power per heater	1.7 kW	1.5 kW
Total power	5.1 kW	9 kW
Recommended RCCB rating	30 mA	30 mA
Transformer		
Output	24 V a.c., 50/60 Hz	24 V a.c., 50/60 Hz
Rating	50 VA minimum	50 VA minimum
Contactors		
Contact current resistive (maximum)	20 A	32 A
Coil voltage	24 V a.c., 50/60 Hz	24 V a.c., 50/60 Hz
Coil power rating	50 VA inrush, 8 VA hold	50 VA inrush, 8 VA hold
Over-current protection setting		
200 V 50/60 Hz	16.4 A	29.0 A
220 V 50/60 Hz	14.9 A	26.3 A
380 V 50/60 Hz	8.7 A	15.2 A
400 V 50/60 Hz	8.2 A	14.5 A
415 V 50/60 Hz	7.9 A	14.0 A
440 V 50/60 Hz	7.5 A	13.2 A
460 V 50/60 Hz	7.1 A	12.6 A
480 V 50/60 Hz	6.9 A	12.1 A
Over-temperature protection system fuses		
Transformer supply	630 mA, 1.25-inch	630 mA, 1.25-inch
Control circuit supply	2.5 A, 20 mm	2.5 A, 20 mm

## 2.5 Pump fluid data

*Note: Edwards Material Safety Data Sheets for the fluids specified in Table 4 are available on request.*

Table 4 - Pump fluid data

	<b>HT10</b>	<b>HT16</b>	
Pump fluid charge (dry)	1750 ml	3000 ml	
Pump fluid charge (wet)	1500 ml	2600 ml	
Pump fluid charge (minimum)	750 ml *	1000 ml	
<b>Pump fluid type</b>	<b>Flash point</b>	<b>Auto-ignition point</b>	<b>Molecular weight</b>
DC704EU	221 °C	500 °C	484
Edwards L9	241 °C	370 °C	407

\* The minimum fluid charge specified above is the charge at 5.1 kW (that is, nominal electrical supply voltage). The minimum fluid charge is a function of input power. At 110% of nominal electrical supply voltage, the minimum fluid charge is 1250 ml. On installations where overvoltage may occur, the minimum fluid charge must be increased accordingly

## 2.6 Construction details

Table 5 - Construction consumables

Brazing	Silver solder (Ag 40.5%)
3CR12 welds	Bostrand 309L
M.I.G. brazing	Bostrand 200 aluminium bronze
TIG ALI welding	Saffire (5% Si)

Table 6 - Construction materials

Item	Material specification	Material description
Main body assembly	3CR12	11.5% chromium non-austenitic stainless steel; high-temperature paint finish
Interior assembly	LM25TF	Aluminium alloy machined castings
	304S12/15	Stainless steel thermal shields and tie-rod
Cool-cap (HT10)	HC101	High-conductivity copper, 3CR12
	3CR12	Electro-less nickel-plated
Cooling-coils	HC101	High-conductivity copper, M.I.G. brazed to body assembly
Electrical-box	CR1	Mild steel, high-temperature paint finish
Radiation shield	304S12/15	Stainless steel, satin finish
Inlet and outlet O-rings and Co-Seals	-	Nitrile
Other O-rings and Co-Seals	-	Fluoroelastomer

Figure 3 - Pump dimensions (mm): HT10 shown

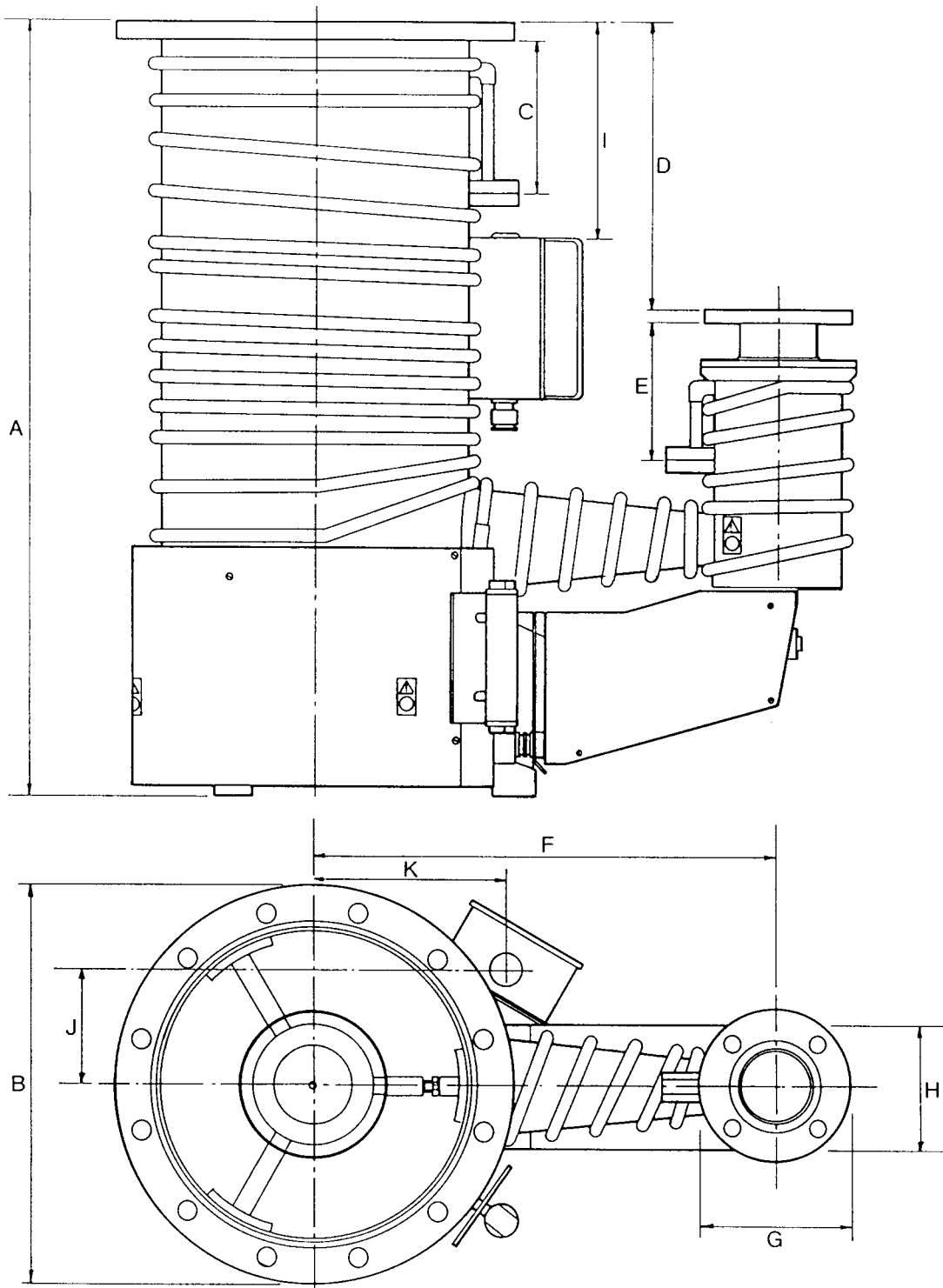

AG/0070/B

Key →	A	B			C	D	E	F	G			H	I	J	K
		ANSI inlet	ISO inlet	EO inlet					ANSI outlet	ISO outlet	EO outlet				
HT10	790	406	370	419	158	295	140	471	152	95	130	127	220	118	197
HT16	1214	597	550	-	222	610	115	610	191	130	-	127	469	175	274

Figure 4 - HT10 performance curves

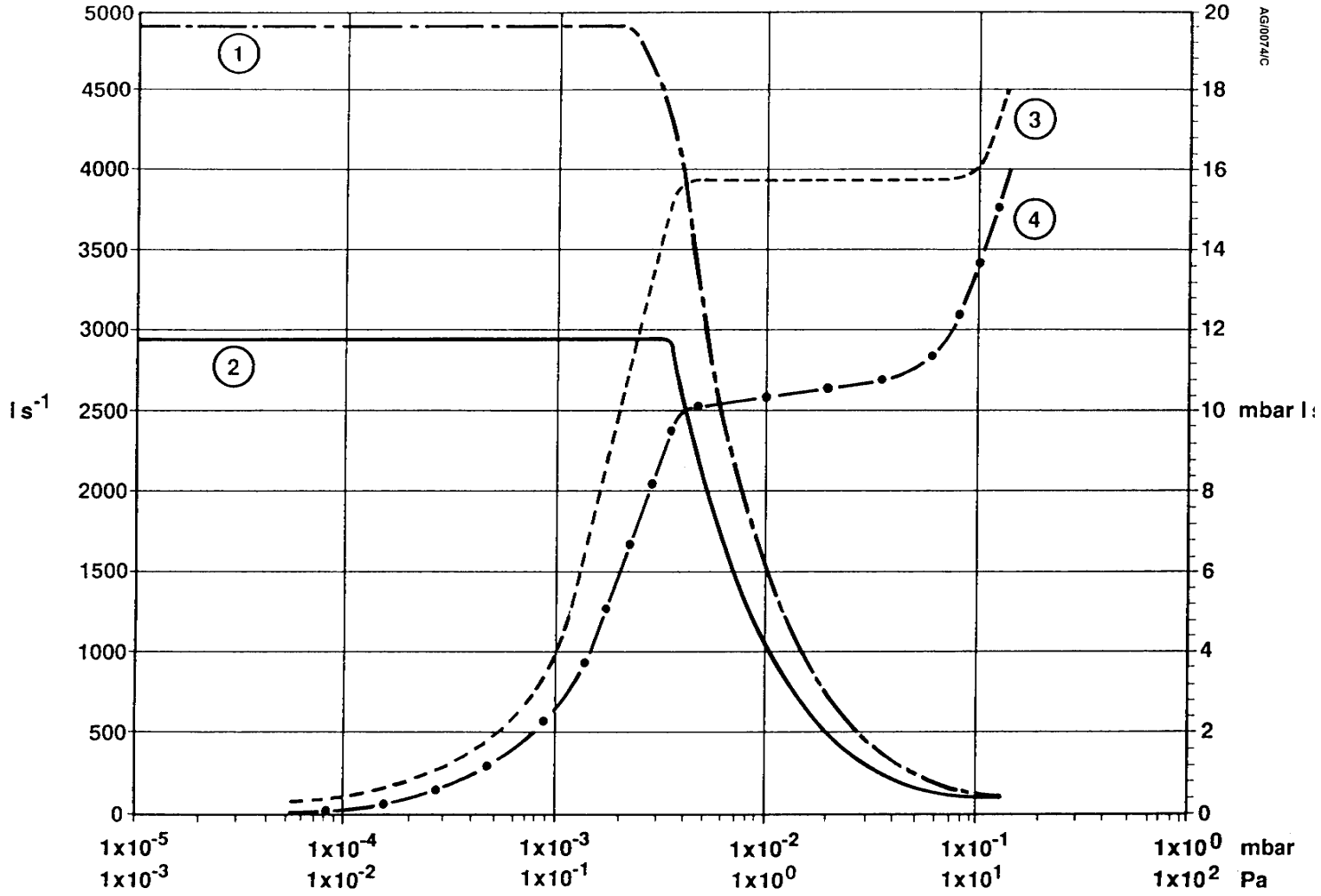

1. Pumping speed ( $l s^{-1}$ ) plotted against pressure (mbar/Pa) for He
2. Pumping speed ( $l s^{-1}$ ) plotted against pressure (mbar/Pa) for N<sub>2</sub>
3. Throughput ( $mbar l s^{-1}$ ) plotted against pressure (mbar/Pa) for He
4. Throughput ( $mbar l s^{-1}$ ) plotted against pressure (mbar/Pa) for N<sub>2</sub>



Figure 5 - HT16 performance curves

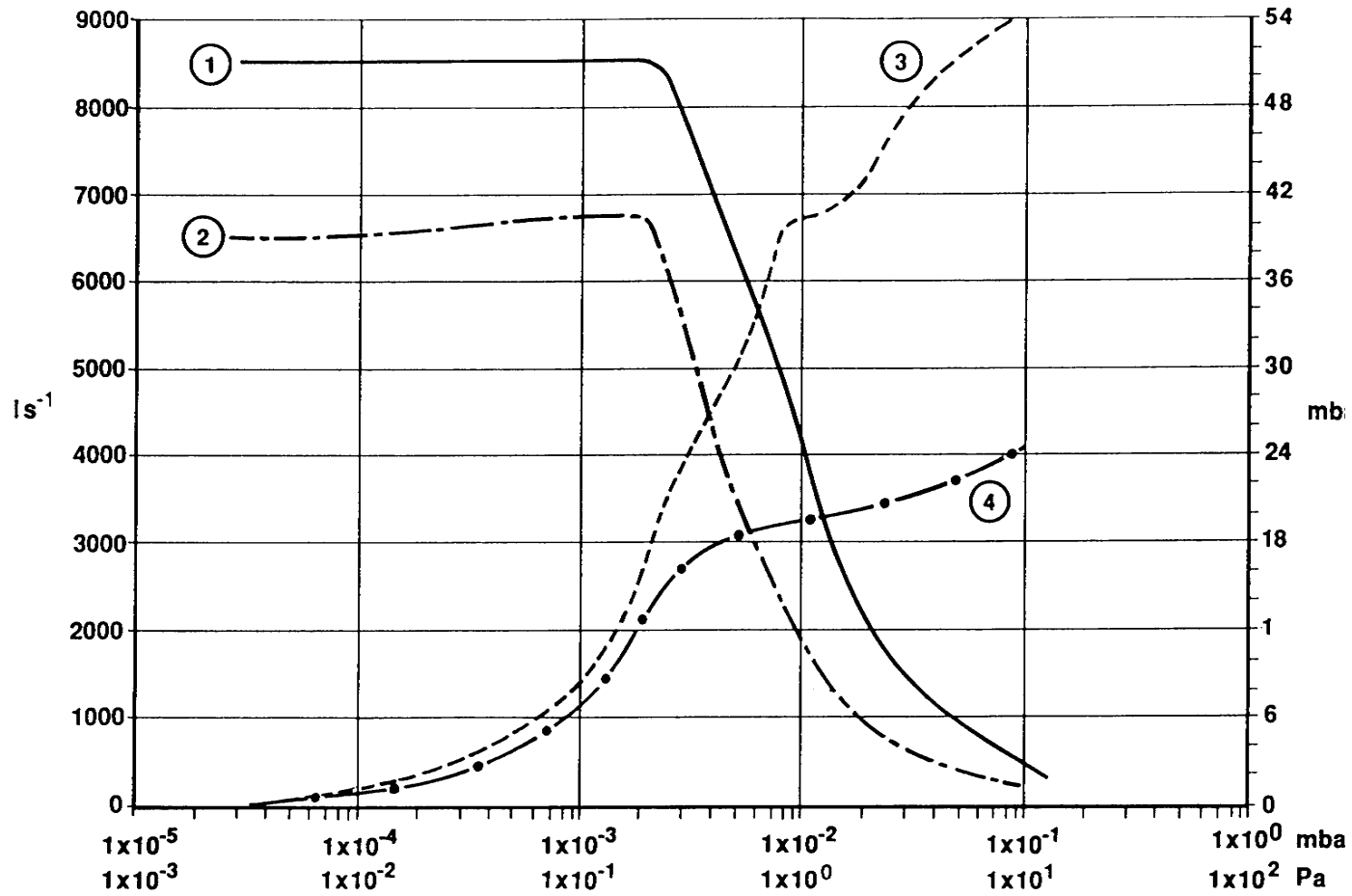

1. Pumping speed ( $l s^{-1}$ ) plotted against pressure (mbar/Pa) for He
2. Pumping speed ( $l s^{-1}$ ) plotted against pressure (mbar/Pa) for air
3. Throughput ( $mbar l s^{-1}$ ) plotted against pressure (mbar/Pa) for He
4. Throughput ( $mbar l s^{-1}$ ) plotted against pressure (mbar/Pa) for air

Figure 6 - Pump warm-up curves: temperature of base flange (°C) plotted against time

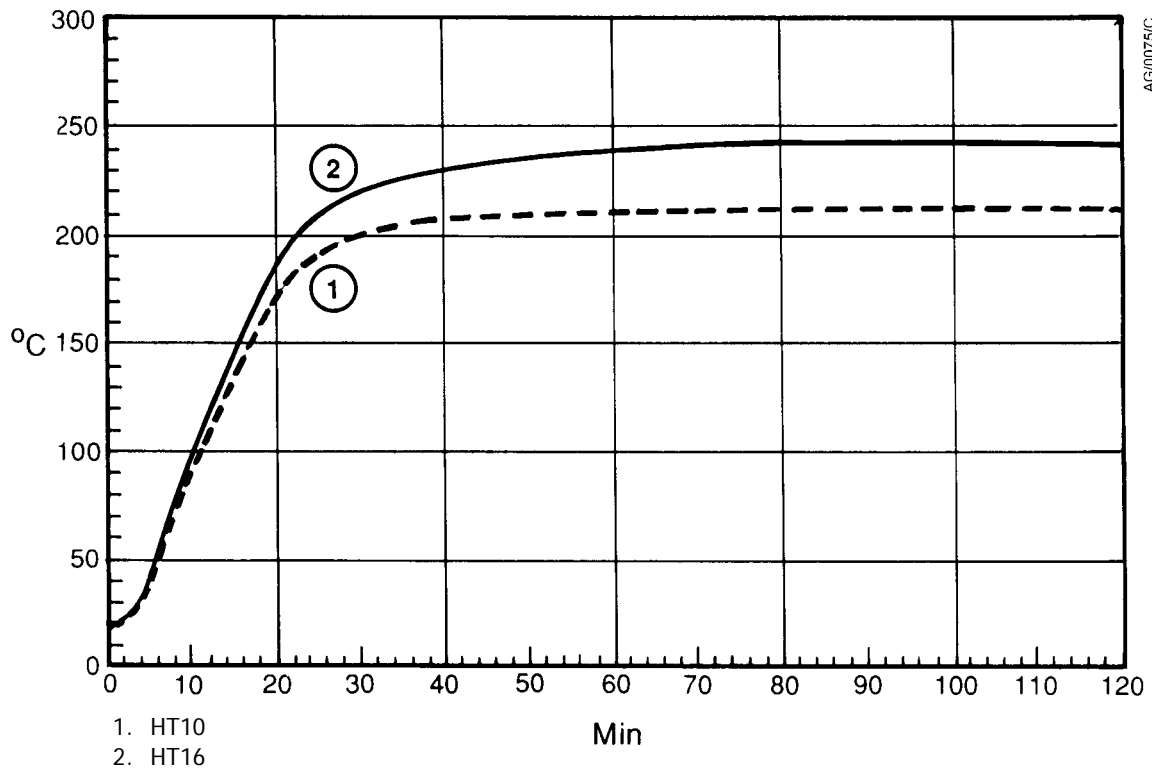
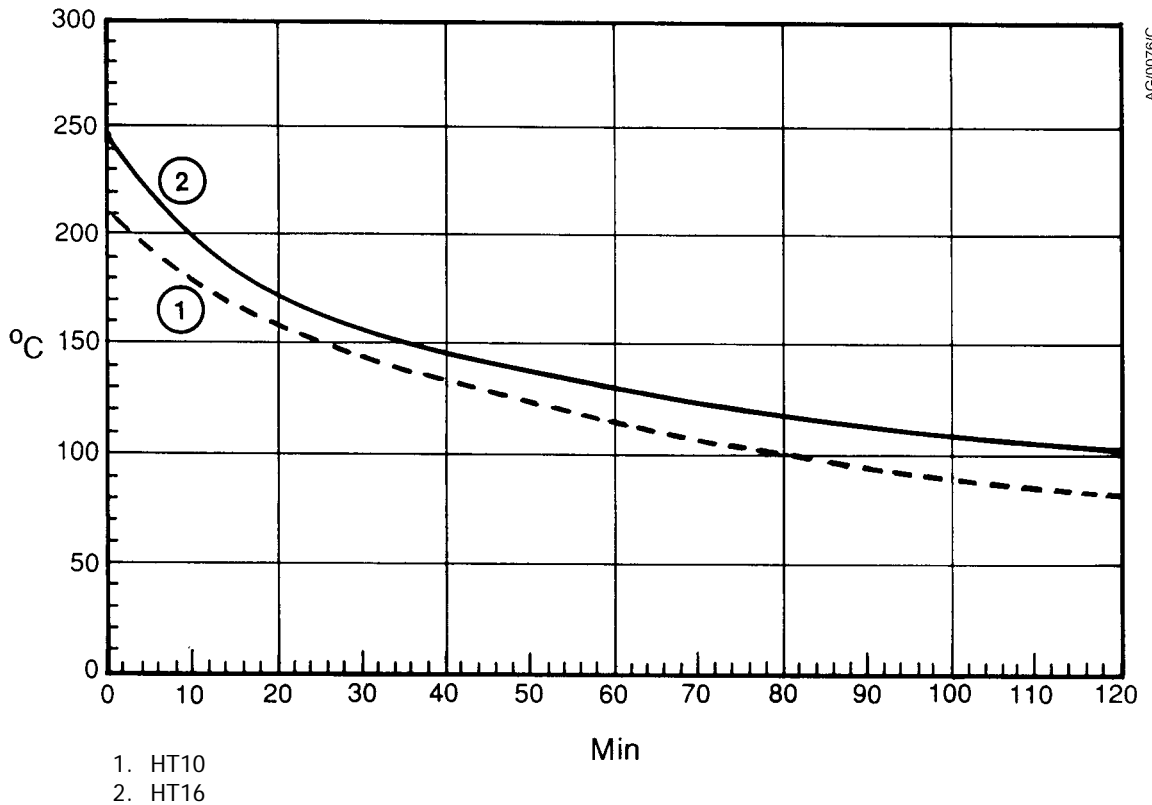

Figure 7 - Pump cool-down curves: temperature of base flange (°C) plotted against time



This page has been intentionally left blank.



## 3 Installation

### 3.1 Unpack and Inspect

Remove all packing materials and protective covers and check the pump. If the pump is damaged, notify your supplier and the carrier in writing within three days; state the Item Number of the pump together with your order number and your supplier's invoice number. Retain all packing materials for inspection. Do not use the pump if it is damaged.

Check that your package contains the items listed in Table 7. If any of these items is missing, notify your supplier in writing within three days. If the pump is not to be used immediately, refit the protective covers. Store the pump in suitable conditions, as described in Section 6.1.

The HT pumps are tested with DC704EU pump fluid before dispatch. All internal surfaces will therefore be coated with a thin film of this fluid. You must clean the pump before you fill it with a fluid other than DC704EU (see Section 3.7).

Table 7 - Checklist of items

Quantity	Description	Check (✓)
1	HT Diffusion Pump	<input type="checkbox"/>
	Fitting-kit, which contains the following:	
1	Auxiliary plug	<input type="checkbox"/>
1	Inlet-port O-ring	<input type="checkbox"/>
1	Outlet-port O-ring	<input type="checkbox"/>

### 3.2 Locate the pump

#### **WARNING**



Use suitable lifting equipment to locate the pump. The mass of the HT10 pump is 80 kg; the mass of the HT16 pump is 185 kg.

#### **WARNING**



Do not touch any part of the pump when it is switched on. Avoid contact between the pump and combustible materials, plastic materials and electrical cables. Surfaces of the pump are very hot and can cause injury to people and damage to equipment.

You must operate the pump with its inlet-flange horizontal and at the top. If the pump will be free-standing, you must support the backing pipeline to stabilize the pump.

Locate the pump at a practical distance from the electrical and cooling-water supplies (see Sections 3.3 and 3.4).

### 3.3 Electrical connections



#### WARNING

A competent electrician must do the electrical installation and maintenance of the pump.



#### WARNING

Ensure that the electrical installation of the pump conforms with your local and national safety requirements. The pump must be connected to a suitably fused and protected electrical supply and a suitable earth (ground) point.

*Note:* An electrical block diagram of the pump is shown in [Figure 8](#).

#### 3.3.1 Pump electrical supply

Connect your electrical supply to the terminal-box as described below; refer to [Figures 1](#) and [2](#) for the locations of the terminal-box and the electrical-box. Optional wiring for electrical cut-out devices is described in [Sections 3.3.2](#) and [3.3.4](#).

As described in [Section 1.4](#), when the pump is switched off, the heaters in the pump will absorb moisture: this will cause a decrease in the insulation resistance of the heaters. We recommend that you connect the electrical supply to the pump through an RCCB (residual current circuit breaker): the RCCB will operate to disconnect the electrical supply if the insulation resistance of the heaters is too small.

For additional electrical safety:

- If you do not use conduit for the electrical installation, use cable which is heat-resistant (up to 150 °C) in case of accidental contact with the pump. You must provide a suitable cable restraint.
  - Fit an emergency stop button, an electrical supply isolator and an over-current trip. Set the over-current trip in accordance with the recommendations given in [Section 2.4](#).
  - Check the earth (ground) continuity of the pump electrical supply before you switch on the pump.
1. Check that your electrical supply voltage corresponds to the voltage stated on the pump rating plate.
  2. Refer to [Figure 10](#). Connect the three phase wires of your electrical supply cable to terminals 8, 9 and 10 (3) in the terminal-box.
  3. Connect the earth (ground) wire of your electrical supply cable to the PE terminal (1) in the terminal-box.
  4. Plug the auxiliary plug (supplied in the fitting-kit) into its socket on the front of the electrical-box. This plug is supplied pre-wired and the pump will not operate if the plug is not fitted.



### 3.3.2 Over-temperature protection

The operating temperature and the position of the thermal snap-switch assembly are factory set for use with DC704EU fluid. If you wish to use other fluid types, please contact your supplier or Edwards for advice.

### 3.3.3 Auxiliary plug connections

As supplied, the auxiliary plug has a wire link between terminals 1 and 2 (see [Figure 9](#)). If you wish to connect the pump to a secondary protection circuit (as described in [Section 1.2.4](#)), use the following procedure :

1. Unscrew and remove the auxiliary plug cover.
2. Remove the link from terminals 1 and 2.
3. Connect your secondary protection circuit across terminals 1 and 2.
4. Refit the auxiliary plug cover.

### 3.3.4 Indicator trip

An auxiliary switch is fitted to the contactor. The switch is normally closed and will open when the contactor opens, that is, when the electrical supply to the heaters is interrupted. The switch circuit is rated at 6 A/480 V maximum.

You can use the switch to control an external electrical circuit, for example, an electrical supply indicator or a trip relay. To use the switch, connect your external indicator or trip circuit to the auxiliary terminals in the electrical-box (see [Figure 10](#)).

Figure 9 - Auxiliary plug wiring

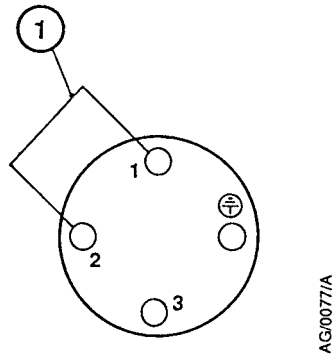

- 1. Link wire

Figure 10 - Terminal-box (with cover removed)

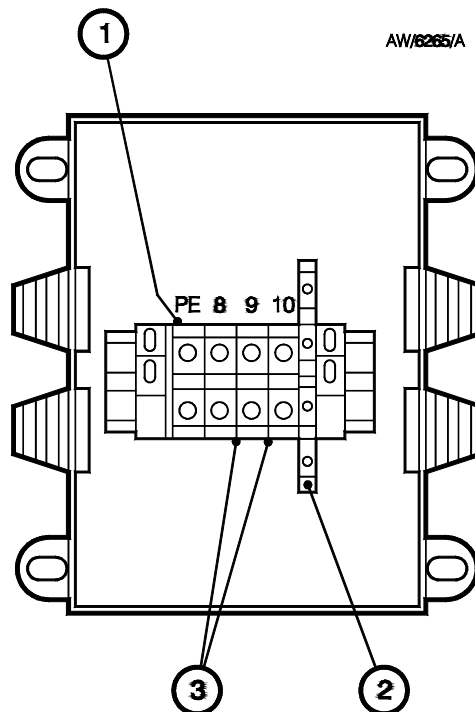

- 1. Earth (ground) terminal
- 2. Auxiliary terminals
- 3. Electrical supply terminals

### 3.4 Cooling-water connections

#### CAUTION

Make sure the cooling-water flows in the correct direction. If it does not, there will be increased backstreaming and loss of performance, which may have an adverse effect on your process

Use the formula below to calculate the minimum required cooling-water flow for the pump:

$$\text{Minimum cooling-water flow (l h}^{-1}\text{)} = \frac{[0.9 \times \text{heater power (W)}]}{4200 \times [35 - \text{water supply temperature (}^{\circ}\text{C)}]} \times 3600$$

If your water supply temperature is 25 °C, you will need a flow of at least 400 l h<sup>-1</sup> for the HT10 pump and 700 l h<sup>-1</sup> for the HT16 pump.

Connect the pump to your cooling-water supply. We recommend that the supply is filtered and that a flow indicator is incorporated into the supply system. Make the cooling-water connections using <sup>3</sup>/<sub>8</sub> inch NPT male fittings for the HT10 or <sup>3</sup>/<sub>4</sub> inch NPT male fittings for the HT16 (these fittings are not supplied). Refer to Figures 1 and 2 for the locations of the following water connections and make sure that:

- The supply flow goes to the water-inlet connection
- The return flow comes from the water-outlet connection.

### 3.5 Vacuum connections



#### WARNING

Conduct the exhaust to a suitable treatment plant to prevent the discharge of dangerous gases and vapours to the surrounding atmosphere.



#### WARNING

If you will pump dangerous substances, you must fit a backing pressure-interlock.

Use the O-rings supplied with the pump or (for the ISO versions of the pump) use Co-Seals (not supplied) to fit the inlet-flange and the outlet-flange to your vacuum system.

Take note of the following recommendations:

- On all applications, we recommend that you fit a backing pressure-interlock to the outlet pipeline to switch off the electrical supply to the pump heaters if the pressure in the pipeline rises to the critical backing pressure. You must fit a backing pressure-interlock if you will pump dangerous substances. If you do not fit a pressure-interlock and the pressure in the outlet pipeline rises to the critical backing pressure, fluid will backstream into the vacuum system and thermal breakdown of the pump fluid may occur (refer to [Section 3.7.1](#)). Note that if you have a suitable backing pressure gauge, you may be able to use the gauge to provide the necessary pressure signal for the pressure-interlock.
- Inspect and clean thoroughly the O-rings and Co-Seals and the O-ring grooves on the pump
- When you place O-rings, make sure that they are not twisted
- To ease installation, coat the O-rings with a light film of the pump fluid
- Before you fit the pump to the system, ensure that all sealing-faces are clean and scratch-free; refinish these faces if necessary.

## 3.6 Leak-test the system

The HT pumps are stringently leak-tested before despatch. After you have installed the pump, leak-test the system before you fill the pump with pump fluid; outgassing from the fluid may give false test results. The pump fluid is viscous at ambient temperatures and may block small leaks.

The level of leak tightness required will depend on the application of your system. You must leak-test the system to ensure the integrity of your vacuum system and its vacuum seals

## 3.7 Fill the pump with fluid

### 3.7.1 Safety of vapour pump fluids

Vapour pump fluids are not dangerous when used in a pump that is operated correctly. But if the pump is operated incorrectly and is allowed to get to very high temperatures, the pump fluid can go through a process of thermal breakdown. The breakdown products which result can be dangerous. [Table 8](#) gives more information about the thermal breakdown of the different vapour pump fluids. Thermal breakdown is more likely to occur if the breakdown temperature is close to the operating temperature of your pump.

### 3.7.2 Recommended pump fluids



#### **WARNING**

Do not use perfluoropolyether (PFPE) pump fluids in the HT10 or HT16 pumps. The thermal breakdown temperature of PFPE fluids is near to the operating temperature of the pump. The thermal breakdown products of PFPE fluids are very dangerous.

Use a silicone fluid (for example, DC704EU) or an alkyl naphthalene fluid (for example, Edwards L9) in the pump.

The thermal breakdown products of some fluids can be dangerous; details of the breakdown products are given in [Table 8](#). The pump has a protection system which prevents the pump from getting to temperatures at which this thermal breakdown occurs.

### 3.7.3 Filling procedure

Use the best fluid for your application. When you first receive the pump, its internal surfaces will be coated with a thin film of DC704EU fluid. This fluid is used to test the pump before dispatch. You must clean the pump before you fill it with a fluid other than DC704EU.

You can refill the pump with the fluid which you last used in the pump. If you want to use a different fluid, you must clean the pump thoroughly before you refill the pump.

Fill the pump with the chosen fluid (see [Section 2.5](#) for fluid charges). Pour the fluid through the inlet-flange or through the dipstick hole. If you pour the fluid through the inlet-flange, do not allow it to flow onto the cool-cap assembly (if fitted). The performance of the pump will be reduced if there is fluid on the cool-cap assembly.

Allow the fluid to drain into the pump for five minutes. Remove the dipstick and check that the fluid-level is visible on the lower (reduced thickness) section of the dipstick. Add more fluid if the fluid-level is low. Drain excess fluid (see [Section 5.4](#)) if the fluid-level is too high.

Table 8 - Vapour pump fluid thermal breakdown

Vapour pump fluid	Edwards Product	Auto-ignition Temp. °C	Break-down Temp. °C	Thermal breakdown products	Type of danger	Possible injury
Silicone fluids (methyl phenyl siloxanes)	DC702, DC704EU, DC705	≈ 500	400	Decomposed hydrocarbons and silicon based species	Negligible	Negligible
Alkyl naphthalene fluid	Edwards L9	70	≈ 300	Naphthalene and decomposed hydrocarbons	Naphthalene is poisonous in large quantities by ingestion and skin contact	Minor (first aid may be required)
Polyphenyl ether (5-Ring)	Santovac® 5	590	≈ 480 (in helium)	Phenol, benzene & phenolic materials	Phenolic materials are poisonous & caustic by ingestion and skin contact	Major (a lost time accident can occur)
Paraffinic fluids & ester fluids	Apiezon® A, B, C, AP201 and AP301	≥ 305	< 300 (in air)	Decomposed hydrocarbons	Fire (Note: AP201 has a low auto-ignition temperature)	Major (a lost time accident can occur)
Perfluoro-polyether	None	None	> 260	Decomposed fluorocarbons including hydrofluoric acid	Highly aggressive materials. Poisonous and caustic by inhalation and skin contact.	Potentially fatal



## 4 Operation

### 4.1 Introduction



#### WARNING

Do not touch any part of the pump when it is switched on. Avoid contact between the pump and combustible materials, plastic materials and electrical cables. Surfaces of the pump are very hot and can cause injury to people and damage to equipment.

*Note:* The temperatures specified in the following sections and on the curves shown in Figures 6 and 7 were measured at the edges of the base flanges of the HT10 pump (Figure 1, Item 41) and the HT16 pump (Figure 2, Item 41). The temperatures and curves are therefore different from those specified for the thermal probe accessory in the EXT Accessories instruction manual.

Sections 4.3 to 4.5 describe the alternative operating procedures applicable to the system configurations shown in Figures 11, 12 and 13. These procedures assume that the HT pump and your vacuum system are at atmospheric pressure. Choose the procedure most suited to your vacuum system. The following basic rules apply to all diffusion pump systems:

- Always turn on the cooling-water supply before you switch on the pump, otherwise the pump will overheat
- Always allow the HT pump to cool for at least 30 minutes before you turn off the cooling-water supply
- Never allow the pressure at the inlet of the pump to rise above 0.1 mbar (10 Pa) when the pump is at operating temperature
- When the pump is at operating temperature, never allow the backing pressure to rise above the critical backing pressure for the fluid used (see Section 2.1)
- Always allow the pump to cool (for at least 60 minutes for the HT10; 90 minutes for the HT16) before the pump-inlet and backing pressures are allowed to rise above their critical values.

## 4.2 Check the insulation resistance of the heaters

If the pump heaters have absorbed moisture while the pump was switched off, the insulation resistance of the heaters may be too low. Use the following procedure to measure the insulation resistance of the heaters before you switch the pump on.

If you have an RCCB in your electrical supply circuit, you do not need to measure the insulation resistance of the heaters because the RCCB will operate to disconnect the electrical supply from the pump if the insulation resistance is too low. If your RCCB has operated, use this procedure to check the insulation resistance of the heaters before you reset the RCCB.

1. Measure the insulation resistance (at 500 V d.c.) between any of the heater terminals (Figure 8, item A) and earth (ground). Then:
  - Multiply the measured resistance by the number of heaters in the pump (defined in Section 2.4), to calculate the insulation resistance per heater.
  - If the insulation resistance per heater is greater than 1 M $\Omega$ , you can switch on the pump.
  - If the insulation resistance per heater is less than 1 M $\Omega$ , continue at Step 2 below.
2. Remove the heaters from the pump (refer to Section 5.9.1). Bake the heaters in an oven at a temperature of 120 °C for 12 hours or more.
3. Remove the heaters from the oven. Measure the insulation resistance of each heater:
  - If a heater has an insulation resistance greater than 1 M $\Omega$ , you can refit the heater to the pump.
  - If a heater has an insulation resistance less than 1 M $\Omega$ , repeat Steps 2 and 3 of this procedure. If the insulation resistance of a heater is less than 1 M $\Omega$  after the heater has been baked for 24 hours, then the heater is faulty and you must replace it with a new heater.

## 4.3 Pump start-up

*Note:* If you do not have an RCCB in your electrical supply circuit, you must check the insulation resistance of the heaters as described in Section 4.2 before you switch on the pump.

### 4.3.1 Fully-valved pumping system

1. Refer to Figure 11. Close all valves and check that all other openings to atmospheric pressure are closed.
2. Turn on the cooling-water supply to the HT pump and switch on the backing/roughing pump (4).
3. Open the backing valve (6) and allow the HT pump to be pumped down through the backing pipeline to a pressure of less than 0.1 mbar (10 Pa).
4. When the pressure in the backing pipeline is less than 0.1 mbar (10 Pa), switch on the electrical supply to the HT pump heaters.
5. Allow sufficient time for the pump to heat up to operating temperature (approximately 40 minutes for the HT10; approximately 80 minutes for the HT16 - see Figure 6).
6. Close the backing valve (6), open the roughing valve (3) and pump down your vacuum system to a pressure of less than 0.1 mbar (10 Pa).
7. Close the roughing valve (3), immediately open the backing valve (6) and then open the high-vacuum isolation-valve (8) slowly, so that you do not stall the pump. Pump down the vacuum system to the pressure required.

### 4.3.2 Partially-valved pumping system

1. Refer to [Figure 12](#). Close all valves and check that all other openings to atmospheric pressure are closed.
2. Turn on the cooling-water supply to the HT pump and switch on the backing pump (5).
3. When the pressure in the backing pipeline is less than 0.1 mbar (10 Pa), switch-on the electrical supply to the HT pump heaters.
4. Switch on the roughing pump (4), open the roughing valve (3) and pump down your vacuum system to less than 0.1 mbar (10 Pa).
5. Allow sufficient time for the pump to heat-up to operating temperature (approximately 40 minutes for the HT10; approximately 80 minutes for the HT16 - see [Figure 6](#)).
6. Close the roughing valve (3) and then open the high-vacuum isolation-valve (7) slowly, so that you do not stall the pump. Pump down your vacuum system to the pressure required.

### 4.3.3 Valveless pumping system

Refer to [Figure 13](#):

1. Close the air-admittance valve (2) and check that all other openings to atmospheric pressure are closed.
2. Turn on the cooling-water supply to the HT pump (4).
3. Switch on the backing pump (3).
4. When the pressure in your vacuum system is less than 0.1 mbar (10 Pa), switch on the HT pump heaters and pump down your system to the pressure required.

## 4.4 Process cycling

In many applications, the HT pump may be run continuously except for maintenance periods. The backing pump must run continuously while the HT pump is at operating temperature to maintain the critical backing pressure. A high-vacuum isolation-valve as shown in [Figures 11](#) and [12](#) is needed to isolate the pump from your vacuum system between process cycles.

### 4.4.1 Re-admission of air to your vacuum system

On valveless pumping systems, use the shut-down procedure in [Section 4.5.4](#).

On valved pumping systems only, close the high-vacuum and roughing valves and open the chamber air-admittance valve.

### 4.4.2 Re-evacuate your vacuum system

On valveless pumping systems use the start-up procedure in [Section 4.3.3](#). On valved pumping systems only, proceed as follows:

1. Close the air-admittance valve(s) and any other openings to atmospheric pressure.
2. Open the roughing valve and pump down your vacuum system to less than 0.1 mbar (10 Pa).
3. Close the roughing valve.
4. Open the high-vacuum valve slowly so that you do not stall the HT pump.

## 4.5 Pump shut-down

### 4.5.1 Introduction

Use the procedures in Sections 4.5.2 to 4.5.4 to shut down the pump.

As described in [Section 1.4](#), when the pump is switched off, the heaters in the pump will absorb moisture: this will cause a decrease in the insulation resistance of the heaters. To avoid the absorption of moisture when the pump is in an environment of high ambient humidity, we recommend that you maintain the base flange temperature at a temperature between 20 and 30 °C above the ambient temperature. Ensure that the base flange does not get too hot; if it does, the pump fluid may vaporise and contaminate the vacuum system.

For more information about the operation of the pump in high ambient humidity, request a copy of our Application Note P400-50-000 from your supplier or Edwards.

### 4.5.2 Fully-valved pumping systems

The following method of shut-down of a fully-valved pumping system ensures that the HT pump is left evacuated and so prevents the absorption of air by the pump fluid. When you subsequently start up, pump down the system through the roughing pipeline to a pressure of less than 0.1 mbar (10 Pa) before you open the backing valve. Refer to [Figure 11](#):

1. Close the high-vacuum isolation-valve (8). Switch off the HT pump heaters and allow the pump to cool (for at least 60 minutes for the HT10; 90 minutes for the HT16). If you do not allow the pump to cool before you admit air, on re-evacuation the pump fluid will superheat and evolve vapour which will pass into the backing pipeline.
2. Close the backing valve (6), then switch off the backing/roughing pump (4).
3. Open the backing pump air-admittance valve (5). If you do not admit air to the backing pump, backing pump oil may be drawn into the backing pipeline.
4. When the HT pump has cooled completely, turn off the cooling-water supply.
5. If required, open the vacuum system air-admittance valve (2) to admit air into the system.

Figure 11 - Fully-valved pumping system

1. Vacuum system
2. Vacuum system air-admittance valve
3. Roughing valve
4. Backing/roughing pump
5. Backing pump air-admittance valve
6. Backing valve
7. HT pump
8. High-vacuum isolation-valve

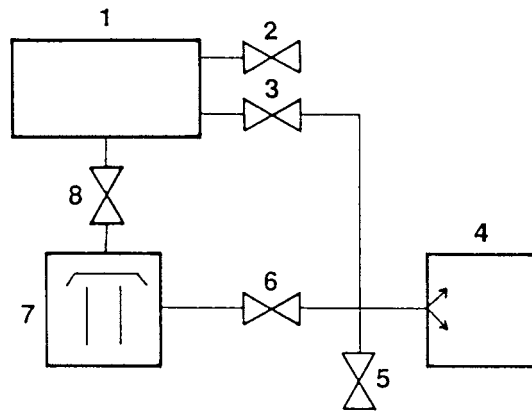

AG/0066/A

Figure 12 - Partially-valved pumping system

1. Vacuum system
2. Vacuum system air-admittance valve
3. Roughing valve
4. Roughing pump
5. Backing pump
6. HT pump
7. High-vacuum isolation-valve
8. HT pump air-admittance valve

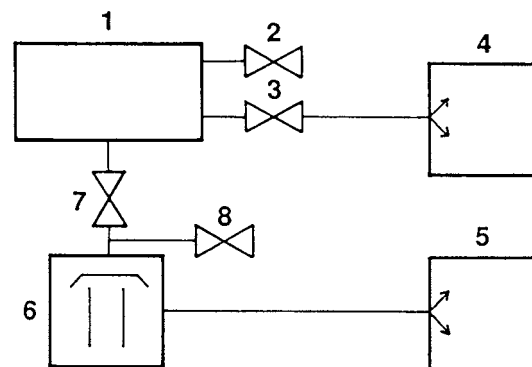

AG/0067/A

Figure 13 - Valveless pumping system

1. Vacuum system
2. Air-admittance valve
3. Backing pump
4. HT pump

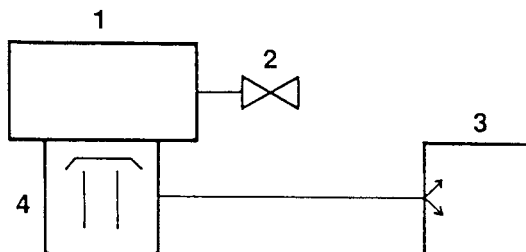

AG/0066/A

### 4.5.3 Partially-valved pumping systems

To shut down a partially-valved pumping system, use the procedure below. Refer to [Figure 12](#):

1. Close the high-vacuum isolation-valve (7).
2. Switch off the HT pump heaters and allow the pump to cool (for at least 60 minutes for the HT10; 90 minutes for the HT16). If you do not allow the pump to cool before you admit air, on re-evacuation the pump fluid will superheat and evolve vapour which will pass into the backing pipeline.
3. Switch off the backing pump (5).
4. Open the HT pump air-admittance valve (8). If you do not admit air to the system, backing pump oil may be drawn into the backing pipeline.
5. When the HT pump has cooled completely, turn off the cooling-water supply.
6. If required, open the vacuum system air-admittance valve (2).

### 4.5.4 Valveless pumping systems

Use the procedure below to shut down a valveless pumping system. Refer to [Figure 13](#):

1. Switch off the HT pump heaters and allow the pump to fully cool.
2. Switch off the backing pump (3).
3. Open the air-admittance valve (2). If you do not admit air into the vacuum system, backing pump oil may be drawn into the backing pipeline.
4. When the HT pump has cooled completely, turn off the cooling-water supply.

## 5 Maintenance

### 5.1 Safety



#### **WARNING**

Obey the safety instructions given below and take note of appropriate precautions. If you do not you can cause injury to people and damage to equipment.

- A suitably trained and supervised technician must maintain the pump.
- Ensure that the maintenance technician is familiar with the safety procedures which relate to the pump fluid and the products pumped. Wear the appropriate safety-clothing when you come into contact with contaminated components. Dismantle and clean contaminated components inside a fume-cupboard.
- Isolate the pump from the electrical supply and your vacuum system before you start maintenance work.
- Allow the pump to cool fully before you touch any part of the pump (including the dipstick and the drain plug) or attempt to move it. Open the pump to atmospheric pressure when it is cool.
- Always allow the pump to cool for at least 30 minutes before you turn off the cooling-water supply.
- Do not remove the dipstick or open the drain-plug to vent the pump while the pump is operating or under vacuum.
- Use suitable lifting equipment when you move the pump (HT10 pump mass is 80 kg; HT16 pump mass is 185 kg).
- Do not touch or inhale the thermal breakdown products of fluorinated materials which may be present if the pump has been overheated to 315 °C and above. These breakdown products are very dangerous. Fluorinated materials in the pump may include seals and O-rings. The pump may have overheated if it was misused, if it malfunctioned or if it was in a fire. Edwards Material Safety Data Sheets for fluorinated materials used in the pump are available on request; contact your supplier or Edwards.
- Do not touch or inhale the thermal breakdown products of the pump fluid if the pump has been overheated.
- Wear suitable eye protection when you work underneath the pump, so that dust or debris cannot get into your eyes.
- Do not use abrasive or reactive chemical substances to clean the pump.
- Do not use solvents to clean O-rings.

## 5.2 Maintenance plan

The plan shown in [Table 9](#) details the maintenance operations necessary to maintain the pump in normal use. Instructions for each operation are given in the section shown.

Table 9 - Maintenance plan

Operation	Frequency	Refer to Section
Check the pump fluid-level	Monthly	5.3
Inspect the pump fluid and drain if necessary	Monthly	5.4
Clean the pump	Yearly	5.5
Clean the condenser	Yearly	5.6
Clean the cooling-coils	Yearly	5.7
Replace the thermal snap-switches	As required	5.8

More frequent maintenance may be required if corrosive or abrasive gases and vapours have been pumped. If necessary, adjust the maintenance plan according to your experience.

## 5.3 Check the pump fluid-level

If the pump boiler operates at a higher than normal temperature, check the level of fluid in the pump boiler as described below.

1. Allow the pump to cool and open it to atmospheric pressure.
2. Remove the dipstick and check the fluid-level. The fluid-level should be visible on the lower (reduced thickness) section of the dipstick.
3. If the fluid-level is low, add more fluid as detailed in [Section 3.7](#).
4. Allow the fluid to drain into the boiler and check the level again. If the level is too high, excess fluid must be drained (see [Section 5.4](#)).
5. Inspect the dipstick O-ring. Replace the O-ring if it is damaged or if thermal set has taken place.
6. Refit the dipstick.

## 5.4 Inspect and drain the pump fluid

If the pump fails to give satisfactory performance on a leak tight system, inspect the condition of the pump fluid. Use the procedure described below; numbers shown in brackets refer to the item numbers given in [Figures 1 and 2](#).

1. Allow the pump to cool and open it to atmospheric pressure.
2. If the pump is cold, switch on the pump heater for a maximum of two minutes to warm the pump fluid. Do not vaporise the pump fluid.
3. Remove the drain-plug (38) and allow the fluid to drain from the pump.
4. Disconnect the pump from the electrical supplies and detach it from your vacuum system.
5. Visually check the interior of the pump.
  - If it is badly discoloured or coated with charred fluid, the pump fluid has deteriorated and must be changed; clean the pump as described in [Section 5.5](#).
  - If the fluid is in a satisfactory condition, refill the pump as described in [Section 3.7](#) and refit it to the system.



## 5.5 Clean the pump



### WARNING

Remove all traces of the cleaning solution before you operate the pump.

When you clean the pump, choose the cleaning solution to suit the type of pump fluid that has been used.

Note that the pump body assembly and all of the components (excluding all electrical items) can be vapour de-greased, but we do not recommend this, as prolonged immersion can damage the external painted finish.

Use the procedure described in Section 5.5.1 or 5.5.2 to clean the pump.

### 5.5.1 Clean the HT10 pump

Refer to [Figure 1](#) for the item numbers in brackets.

1. Drain the pump fluid as described in [Section 5.4](#).
2. Disconnect the cooling-water supply and drain the pump of water.
3. Slacken the cool-cap clamping nut. Remove the cool-cap assembly (1) from the pump-inlet.
4. Remove the spring, secondary-cap, and top-jet cap (2, 30 and 31). Remove the interior tie-rod (20, located under the top-jet cap) and the spring, disk and split pin assembly (23).
5. Lift out the remaining jet stages (19, 21, 22) the centre tube (18), the oil drier assembly (16) and the thermal shields (42, 43).
6. Wash the pump interior and internal components with the selected cleaning solution.
7. Wash again with acetone to remove all traces of the cleaning solution. Bake to 77 °C to remove the acetone. Alternatively, pass warm air over the components and the pump interior.
8. Inspect the outlet-condenser assembly (11). If the pump has been used in heavily contaminated processes, it may be necessary to disassemble and clean the condenser as described in [Section 5.6](#).
9. Inspect all of the O-rings; replace any that are damaged or that have undergone thermal set. Use dry, lint-free cloth or paper to clean the undamaged O-rings. Ensure that all O-rings are dust-free before reassembly.
10. Check that all sealing-faces are scratch-free. Refinish surfaces that are scratched.
11. Reassemble the pump: use Steps 1 to 5 in reverse order. When you reassemble the pump, take note of the following:
  - When you refit the lower-stage (19), ensure that the outer thermal shield is set correctly on the locating-pin (14). Ensure that the pin engages correctly into the locating slot in the pump base.
  - When you refit the top-cap assembly, you must set the top-jet cap pin so that it is flush with the top surface of the cool-cap. For optimum pump efficiency, set the cool-cap parallel to the top flange.
  - When you refit the cool-cap assembly, tighten the clamping nut just sufficiently to hold the assembly in position. You will damage this assembly if you overtighten it.

### 5.5.2 Clean the HT16 pump

Refer to [Figure 2](#) for the locations of the item numbers in brackets.

1. Drain the pump fluid as described in [Section 5.4](#).
2. Disconnect the cooling-water supply and drain the cooling-water from the pump.
3. Disconnect and remove the cooling-water feed tubes to the cool-cap.
4. Remove the three water boss mounting screws (35, these are the least recessed screws) and remove the water boss (34), or ease the water boss clear of the pump-body.
5. Remove the three remaining cool-cap boss mounting screws.
6. Remove the fixing screw, special washer and ceramic washer (26, 27, 28) in the centre of the cool-cap (24) and lift the assembly clear of the pump. Take care not to displace the O-rings (29) when you remove this assembly.
7. Remove the ceramic spacer (29) from the top-jet cap (30).
8. Remove the secondary-cap (25). Remove the three fixing screws and the top-jet cap (30) from the top of the interior assembly.
9. Remove the interior fixing bolt, spring and washer assembly (23) from the tie-rod (19).
10. Lift out the remaining jet stages (18, 20, 21, 22), the centre tube (17), the oil drier assembly (15) and the thermal shields (42, 43).
11. Wash the pump interior and internal components with the selected cleaning solution.
12. Wash again in acetone to remove all traces of the solution. Bake to 77 °C to remove the acetone. Alternatively, pass warm air over the components and the pump interior.
13. Inspect the outlet-condenser assembly (10). If the pump has been used in heavily contaminated processes, it may be necessary to disassemble and clean the condenser as described in [Section 5.6](#).
14. Inspect all of the O-rings; replace any that are damaged or that have undergone thermal set. Use dry, lint-free cloth or paper to clean the undamaged O-rings. Ensure that all O-rings are dust-free before reassembly.
15. Check that all sealing-faces are scratch-free. Refinish surfaces that are scratched.
16. Reassemble the pump: use Steps 3 to 10 in reverse order. When you reassemble the pump, take note of the following:
  - Centralise each interior jet-stage as you reassemble the pump.
  - Before you fit the cool-cap to the pump, ensure that the top-jet assembly is centralised within the pump-inlet.
  - When you refit the lower-stage (18), ensure that the outer thermal shield is set correctly on the locating-pin (13). Ensure that the pin engages correctly into the locating slot in the pump base.
  - When you refit the cool-cap, tighten the fixing screw (26) to 1.4 N m.

## 5.6 Clean the condenser assembly



### WARNING

Remove all traces of the cleaning solution before you operate the pump.

It is normally sufficient to clean the condenser assembly as described in [Section 5.5](#), as this procedure will remove the majority of fluid and particulate materials in the condenser.

However, if the pump has been used in a heavily contaminated process, the internal baffle assembly may become partially blocked. This will reduce the pump's efficiency. Under these circumstances, clean the condenser as described below. Refer to [Figures 1 and 2](#) for the locations of the item numbers in brackets.

1. Isolate the pump, allow it to cool and open it to atmospheric pressure.
2. Disassemble the backing pipeline from the pump outlet-flange or remove the pump from your vacuum system.
3. Use a hexagonal key to remove the six fixing screws (40) from the top of the condenser assembly (eight screws in the HT16). Lift the outlet-flange assembly clear of the condenser.
4. Remove the three baffle mounting screws (39) and disassemble the baffle. (On the HT16 pump, you can remove the internal nut and lift out the centre baffle).
5. Clean and dry the condenser assembly components.
6. Reassemble the condenser; use Steps 1 to 4 above in the reverse order. Note that a small pin is located on the condenser to assist in the correct location of the outlet-flange assembly.

## 5.7 Clean the cooling-coils

The cooling-coil should be cleaned at least once a year, and more regularly if the water supply has a high calcium content.

To clean the cooling-coil, flush with a suitable descaler. For example, a 15% hydrochloric acid solution can be used for decalcification followed by a 5% sodium carbonate solution for neutralization.

## 5.8 Replace the thermal snap-switch

**Note:** *The cooling-coil thermal snap-switch has a longer mounting stud than the pump base (boiler) thermal snap-switch. The cooling-coil thermal snap-switch must be fitted so that it is uppermost on the thermal strap, as shown in [Figure 14](#).*

If you need to replace the thermal snap-switches, check and correct the cause of failure before the pump is returned to service. Refer to [Figure 14](#) and use the procedure below to replace the thermal snap-switches.

1. Remove the retaining nuts from both thermal snap-switches (1, 3) and remove the thermal snap-switches from the thermal strap (2). Release the grommet from the enclosure.
2. Remove the six screws which fix the electrical tray to the lid assembly.
3. Lower the electrical tray just sufficiently to enable the two leads to be disconnected from the auxiliary socket terminal 2 and the terminal on the contactor.
4. Withdraw the assembly together with the grommet from the rear of the enclosure.
5. Refit the assembly: use Steps 1 to 4 above in reverse order.

## 5.9 Heater maintenance

### 5.9.1 Remove the heaters

**CAUTION**

Take care when you remove the mica insulators, which become brittle after long use.

Figures 15 and 16 show the HT10 and HT16 pump heater assemblies. Use the procedure below to remove the heaters.

1. Drain the pump and remove the interior assemblies as described in Sections 5.4 to 5.6.
2. Isolate the pump from the electrical supply.
3. Remove the three screws (four screws in the HT16) which secure the perforated shield to the pump base. Lift the shield clear of the pump.
4. Remove the three radiation shield mounting nuts and washers (six nuts and washers from the HT16). Remove the shield and mica insulator.
5. Remove the three M6 terminal nuts and washers from the main terminal-block, together with the three electrical supply leads. Remove the terminal nuts from the heater terminals. Lift the bus bars and the second insulator clear of the base assembly.
6. Remove the M16 nut and washer from the centre stud of each heater. Remove the heaters from the base assembly.

Figure 14 - Thermal snap-switches

1. Cooling-coil thermal snap-switch
2. Thermal strap
3. Pump base (boiler) thermal snap-switch
4. Electrical-box

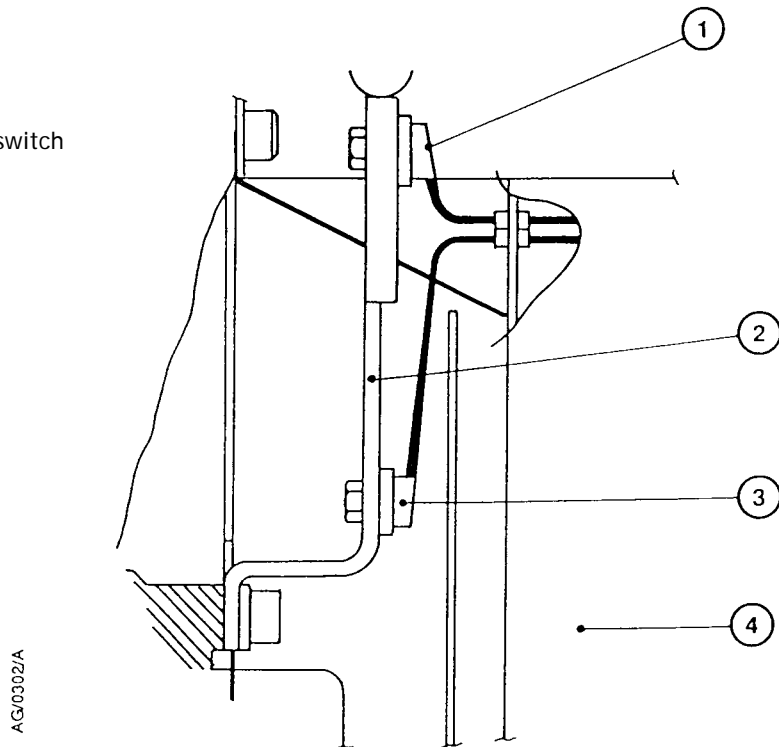

AG/0302/A

### 5.9.2 Fit the new heaters



#### WARNING

After you have replaced a heater, check the phase to earth (ground)/insulation resistance before you reconnect the pump to the electrical supply.

To fit the new heaters, use the procedure below.

1. Inspect the base assembly and check that it is flat and undistorted. If it is distorted, contact Edwards or your supplier.
2. Place the heaters over the studs with the terminals in approximately their final positions. Coat the threads lightly with a heat-resistant anti-seize compound and screw the fixing nuts down, finger-tight only.
3. Inspect the mica insulators removed in [Section 5.9.1](#). If the insulators are damaged, replace them with new insulators.
4. Place the mica insulator over the heater studs; ensure that it clears the heater terminals.
5. Place the bus bars in position and ensure that the terminal-block and heater terminations are correctly connected; rotate the heaters to allow the bus bars to align with the heater and terminal-block terminations (see [Figures 15 and 16](#)). Lightly screw down the M6 terminal nuts.
6. Reassemble the three electrical supply leads onto the terminals and lightly screw down the M6 terminal nuts.
7. Tighten the heater fixing nuts to a maximum torque of 54 N m (40 lbf ft). Check that there is a minimum air-gap of 12 mm between all of the conductors and fully tighten all the heater and electrical supply terminal nuts.
8. Refit the outer mica insulator and the radiation shield. Refit and fully tighten all the fixing nuts.
9. Refit the lower heat shield and tighten the fixing screws.
10. Check the phase to earth (ground) leakage current/insulation resistance before you reconnect the pump to the electrical supply.

## 5.10 Replace electrical components

To allow replacement of any of the components in the electrical-box, the lower tray assembly complete with the components may be removed as a single unit. To remove the tray, use the procedure described below.

1. Isolate the pump from the electrical supply.
2. Remove the auxiliary plug from the pump.
3. Support the tray and remove the six fixing screws from the side of the electrical-box.
4. Lower the tray sufficiently to remove the three earth-bonding straps from the main earth (ground) stud.
5. Remove the three black fibreglass-covered heater leads, the two auxiliary contact leads from their respective terminals and the three electrical supply leads from the contactor at the rear of the tray. If the heater assembly has been disassembled, the heater leads can be passed through into the electrical-box: you do not need to disconnect them from the contactor.
6. Remove the two thermal snap-switch leads from the auxiliary socket terminal 2 and the contactor terminal.
7. Remove the component tray and carry out the required inspection, test or replacement of components.

To reassemble the electrical-box, use Steps 1 to 7 above in reverse order. When you reassemble the electrical component tray or the heaters onto the pump, check that the ceramic-wool packing in the leadthrough is still in place. If the ceramic-wool packing is not in place, excessive heat will build up within the electrical-box.

Figure 15 - HT10 pump base (with outer radiation shield removed)

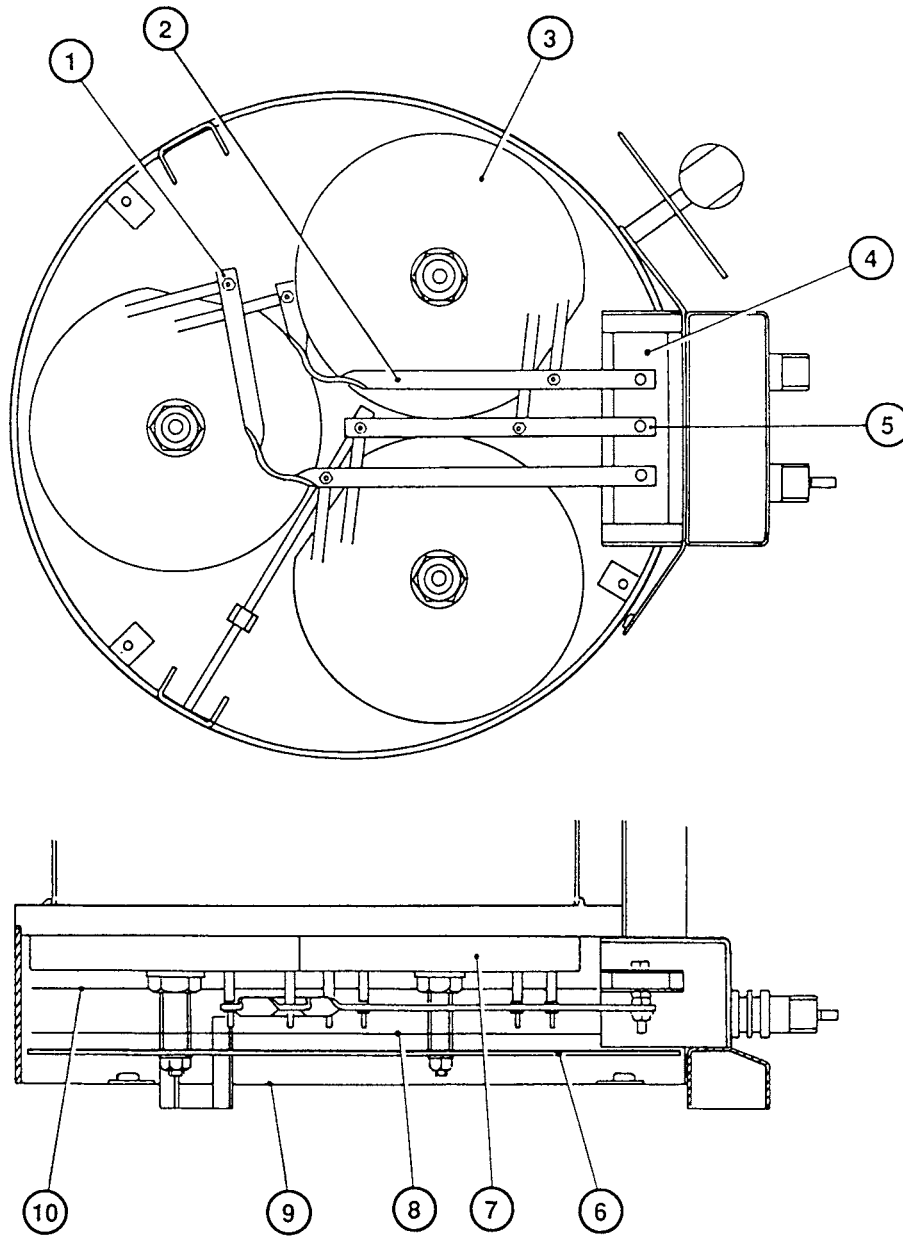

AG/0073/A

- |                    |                           |
|--------------------|---------------------------|
| 1. Bus bar 1       | 6. Radiation shield       |
| 2. Bus bar 2       | 7. Heater assembly        |
| 3. Heaters (3 off) | 8. Outer insulating disk  |
| 4. Terminal block  | 9. Outer shield           |
| 5. Bus bar 3       | 10. Inner insulating disk |

Figure 16 - HT16 pump base (with outer radiation shield removed)

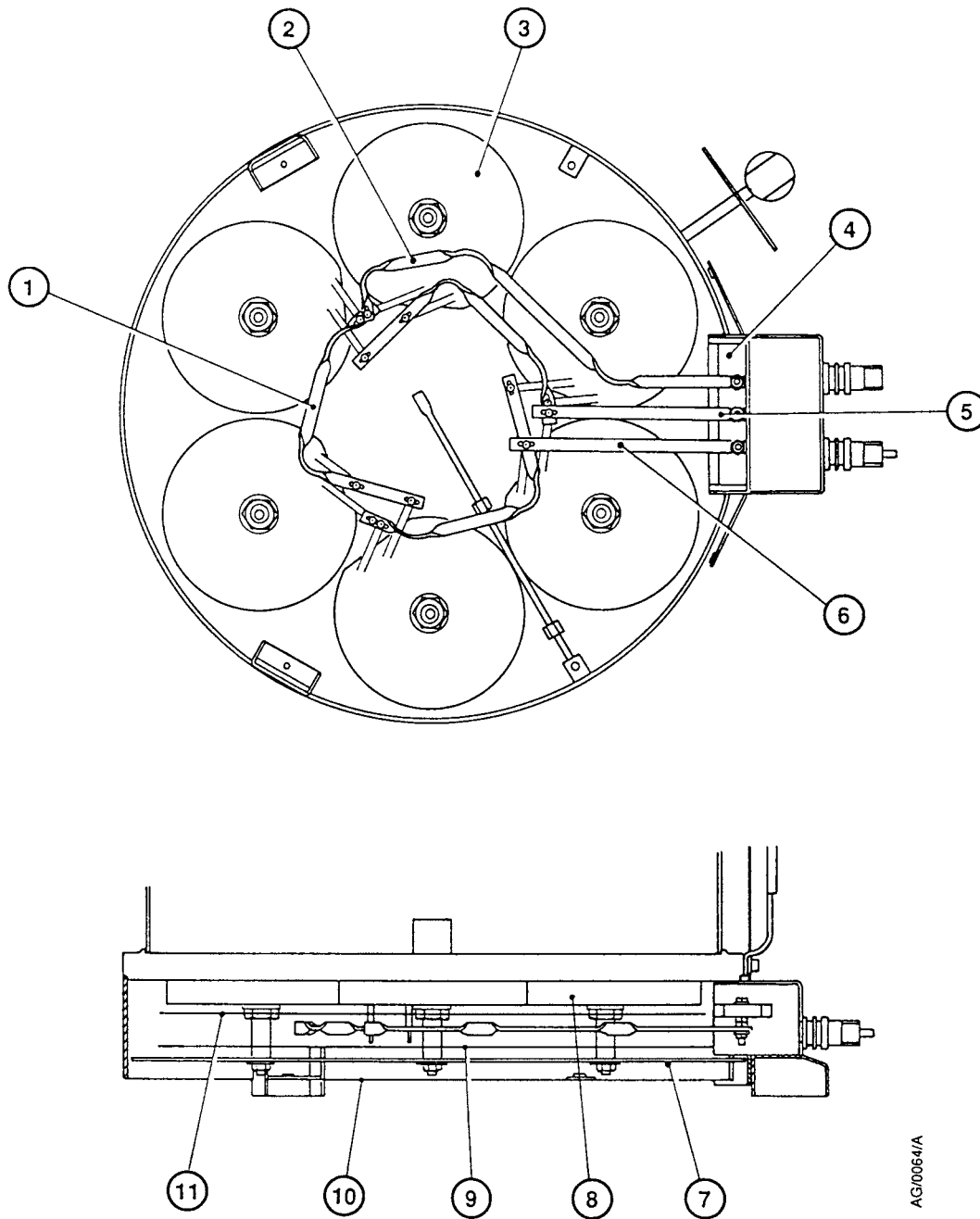

- |                      |                                   |
|----------------------|-----------------------------------|
| 1. Bus bar 1 (3 off) | 7. Radiation shield               |
| 2. Bus bar 2         | 8. Heater assembly                |
| 3. Heaters (3 off)   | 9. Outer insulating disks (2 off) |
| 4. Terminal block    | 10. Outer shield                  |
| 5. Bus bar 4         | 11. Inner insulating disk         |
| 6. Bus bar 3         |                                   |

## 5.11 Fault finding

A list of fault conditions and their possible causes is provided here to assist you in basic fault finding. If problems persist, contact your supplier or your nearest Edwards Service Centre.

### 5.11.1 The pump will not start

- The electrical supply connections are disconnected.
- A fuse has failed.
- The electrical supply thermal overload has tripped.
- A component has failed.
- The auxiliary plug is disconnected or missing.

### 5.11.2 The pump shuts down

- The electrical supply connections have become disconnected.
- A fuse has failed.
- The electrical supply thermal overload has tripped.
- The thermal snap-switch has operated.
- A component has failed.
- The auxiliary connector has become disconnected.
- An auxiliary plug link is missing.

### 5.11.3 The pump fails to achieve specified performance

- The pump fails to reach ultimate vacuum or low-pressure pumping speed (below  $1 \times 10^{-3}$  mbar,  $1 \times 10^{-1}$  Pa) is poor.
- There is a leak in your vacuum system.
- There is a leak in the pump.
- The pump fluid is contaminated.
- Your vacuum system is contaminated.
- The heater has failed.
- The cool-cap is misaligned.
- The pump has been filled with new pump fluid.
- The cooling-water temperature is too high.
- Your pressure gauge is incorrectly calibrated.



#### 5.11.4 High-pressure pumping speeds (above $1 \times 10^{-3}$ mbar, $1 \times 10^{-1}$ Pa) are poor

- The backing pump is too small.
- The backing pump is faulty.
- There is a leak in the backing pipeline.
- The fluid-level is incorrect.
- There is a restriction in the pump-outlet.
- The pump interior assembly is installed incorrectly.
- The pump heater has failed.
- The diameter of the backing pipeline is too small or the backing pipeline is too long.

#### 5.11.5 Pumping is unstable

- The fluid return to the pump boiler is restricted.
- The pump fluid-level is low.

#### 5.11.6 Pressure is unstable

- The pump fluid-level is incorrect.
- The cool-cap is misaligned.
- The cooling-water flow is restricted.
- The pump interior assembly is assembled incorrectly.
- The cooling-water temperature is too high.

#### 5.11.7 Backstreaming is excessive

- The cool-cap is misaligned.
- The secondary cool-cap is missing.
- The cooling-water temperature is too high.
- The cooling-water flow is restricted.

#### 5.11.8 Pump fluid loss is excessive

- The pump-outlet condenser is missing.
- The cooling-water flow is restricted.
- The cooling-water temperature is too high.
- The pump is stalled due to a high gas load or high backing pipeline pressure.

This page has been intentionally left blank.

## 6 Storage and disposal

### 6.1 Storage

Use the procedure below to store the pump:

1. Shut down the pump as described in [Section 4.5](#).
2. Isolate the pump from the electrical supply, disconnect it from your vacuum system and drain the pump fluid as described in [Section 5.4](#).
3. Clean the pump as described in [Section 5.5](#).
4. Reassemble the pump as described in [Section 5.5](#). Do not refill the pump with fluid.
5. Place protective covers over the inlet and outlet-flanges and the cooling-water supply and return connectors.
6. Store the pump in cool dry conditions until it is required for use. We recommend that you store the pump in an air-conditioned environment to prevent the absorption of moisture by the pump heaters.
7. When required, prepare and install the pump as described in [Section 3](#).

### 6.2 Disposal

Dispose of the pump and any components removed from it safely in accordance with all local and national safety and environmental requirements.

Take particular care with the following:

- Components which have come into contact with pump fluid
- Fluoroelastomers which may have been subjected to temperatures above 260 °C (see [Section 5.1](#))
- Components which have been contaminated with dangerous process substances.

This page has been intentionally left blank.

## 7 Service, spares and accessories

### 7.1 Introduction

Edwards products, spares and accessories are available worldwide from Edwards companies and our network of distributors. Please refer to the back page of this manual or to [www.edwardsvacuum.com](http://www.edwardsvacuum.com) for contact information.

Order spare parts and accessories from your nearest Edwards company or distributor. When you order, please state for each part required:

- Model and Item Number of your equipment.
- Serial number (if any).
- Item Number and description of the part.

### 7.2 Service

Edwards products are supported by a worldwide network of Edwards Service Centres. Each Service Centre offers a wide range of options including: equipment decontamination; service exchange; repair; rebuild and testing to factory specifications. Equipment which has been serviced, repaired or rebuilt is returned with a full warranty.

Your local Service Centre can also provide Edwards engineers to support on-site maintenance, service or repair of your equipment.

For more information about service options, contact your nearest Service Centre or other Edwards company.

### 7.3 Spares

The spare parts available from Edwards for the HT10 and HT16 diffusion pumps are listed in the following Sections.

### 7.3.1 HT10 spares

Spare	Item Number
Drain/filler assembly O-ring (fluoroelastomer) : pack of 5	H021-06-022
ANSI10 inlet-port O-ring (fluoroelastomer)	H021-06-099
EO 12 inch inlet-port O-ring (nitrile)	H021-05-101
ISO320 inlet-port trapped O-ring (neoprene)	B311-03-081
ANSI2 outlet-port O-ring (nitrile) : pack of 5	H021-05-053
EO 130 mm outlet-port O-ring (nitrile) : pack of 5	H021-05-055
ISO63 outlet-port Co-Seal (nitrile)	B271-58-176
Mica insulators pack	B311-01-092
Bus bar pack	B311-01-093
Fluid heater (1700 W)	
200 V	H017-06-010
220 V	H017-06-011
380 V	H017-06-012
400 V	H017-06-013
415 V	H017-06-014
440 V	H017-06-018
460 V	H017-06-015
480 V	H017-06-016

### 7.3.2 HT16 spares

Spare	Item Number
Drain/filler assembly O-ring (fluoroelastomer) : pack of 5	H021-06-022
ANSI16 inlet-port O-ring (nitrile)	H021-24-149
ANSI3 outlet-port O-ring (nitrile) : pack of 2	H021-05-059
ISO500 inlet-port trapped O-ring (neoprene)	B312-05-081
ISO100 outlet-port Co-Seal (nitrile)	B271-58-177
Cool-cap O-ring kit (1 off)	B312-04-066
Mica insulators pack	B312-04-092
Bus bar pack	B312-04-093
Fluid heater (1500 W)	
200 V	H017-06-020
220 V	H017-06-021
380 V	H017-06-022
400 V	H017-06-023
415 V	H017-06-024
440 V	H017-06-028
460 V	H017-06-025
480 V	H017-06-026

### 7.3.3 Spares common to HT10 and HT16

Spare	Item Number
DC704EU pump fluid (500 ml)	H112-01-040
Edwards L9 pump fluid (500 ml)	H115-01-016
Thermal snap-switch assembly	B311-01-090
Auxiliary fuse pack *	B311-01-091
Heater lead pack	B312-04-094

\* Contains 630 mA x 1.25-inch fuses (3 off) and 2 A x 20 mm fuses (3 off).

## 7.4 Accessories

### 7.4.1 Thermal probe

**Note:** The temperatures specified in this manual and on the curves shown in Figures 6 and 7 were measured at the edges of the base flanges of the HT10 pump (Figure 1, Item 41) and the HT16 pump (Figure 2, Item 41). The thermal probe does not sense the temperature at the same point of the pump. The temperatures and curves in this manual are therefore different from those specified for the thermal probe accessory in the EXT Accessories instruction manual.

The thermal probes sense changes in temperature at the base flange of the pump. The electrical output of the probe can be used (with a suitable panel meter or warning device) to indicate when the fluid-level is low or when the pump-heater has failed.

Accessory	Item Number
Thermal probe for HT10	B611-01-000
Thermal probe for HT16	B612-01-000

### 7.4.2 Heat shield

When fitted, the heat shield ensures that there are no easily accessible surfaces on the pump which are hotter than 75 °C.

Accessory	Item Number
Heat shield for HT10	B611-05-000
Heat shield for HT16	B612-05-000

### 7.4.3 Inlet baffle

The inlet baffle reduces backstreaming of pump fluid (to less than  $5 \times 10^{-5} \text{ mg cm}^{-2} \text{ min}^{-1}$ ) with only a small loss of pump performance.

The inlet baffle accessory is only available for the HT16 pump, as the HT10 pump has a cool-cap which performs the same function as the inlet baffle.

Accessory	Item Number
Inlet baffle for HT16	B612-03-000